

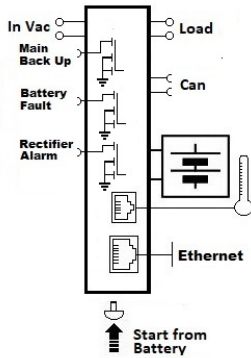

EA-0424

# JDI6024A

Your Power House  
VP ELECTRONIQUE



**Input: Single-phase 115 - 230 - 277 Vac**  
**Output Selectable Load: 24Vdc 2.5A**  
**Output Battery charging: 24 Vdc 2.5A**  
**Suited for the following battery types: Open Lead Acid, Sealed Lead Acid, lead Gel, Ni-Cd, Li-Ion**  
**Automatic diagnostic of battery status, Battery Life Test function (internal Battery Impedance)**  
**Charging curve IUoU, constant voltage and current**  
**Four charging levels: Boost, Bulk, Trickle, Recovery**  
**Protected against short circuit and inverted polarity**  
**Signal output: for battery Fault, Mains or Back-UP**  
**Ethernet: SNMP & Modbus TCP/IP**  
**DIN rail and Wall mount**

**Power Management:** Thanks to the All In One units (DC-UPS), it will be possible to optimize power management. The available power is automatically allocated between load and battery, supplying power to the load is the first priority of the unit thus it is not necessary to double the power, because also the power going to the battery will go to the load if the load so requires. The maximum available current on the load output is 3 times the value of the device rated current in.

**Battery Care:** it's the concept base on algorithms that implement rapid and automatic charging, four state of charge, battery charge optimization during time, flat batteries recovery and real time diagnostic during installation and operation. The Real Time Auto-diagnostic system, monitoring battery faults such as, battery Sulfated, elements in short circuit, accidental reverse polarity connection, disconnection of the battery, they can easily be detected and removed by help of Blink Code of Diagnosis Led; during the installation and after sell. The continuous monitoring of battery efficiency, reduces battery damage risk and allows a safe operation in permanent connection. Each device is suited for all battery types, by means of jumpers it is possible setting predefined curves for Open Lead Acid, Sealed Lead Acid, Gel, Ni-Cd(option). They are programmed for two charging levels, boost and trickle, but they can be changed to single charging level by the user. A rugged casing for DIN rail mounting, IP20 protection degree. They are extremely compact and cost effective.

**Interconnections:** The platform communication for RS485, RS232, CAN, Modbus, SNMP & Modbus TCP/IP or SNMP technology. You can select any of the two buses depending on the application. It allows to communicate with all the accessories provided by AC&E and to develop an independent system for electrical continuity. At the same time, it allows monitoring and control all parameters in the system, even from the other side of the world, by means of application tools on the cloud. All the monitoring and control is very simple but sophisticated monitoring and control for your energy system and opens your mind to new ways to approach your applications. The company allows you to implement very simple but sophisticated monitoring and control for your energy system and opens your mind to new ways to approach your applications.

**Norms and Certifications**  
 The CE mark in conformity to EMC 2014/30/EU: Electromagnetic Compatibility Directive; 2014/35/EU: Low Voltage Directive; ROHS 2011/65/EU: Restriction of the use of certain Hazardous Substances in Electrical and Electronic Equipment (RoHS), as amended by 2015/863/EU. EMC Immunity: EN61000-6-2; EMC Emission: EN61000-6-3. According to: Electrical Equipment for Machinery EN 60204; Electrical safety (of information technology equipment) IEC/EN EN62368-1.

Climatic Data	
Ambient temperature (operation)	-25 ÷ +70 °C
De Rating T° > 50°C	- 2.5%(In) / °C
Ambient temperature Storage	-40 ÷ +85 °C
Humidity at 25 °C no condensation	95% to 25°C
Cooling	Auto convection

General Data	
Insulation voltage (IN/OUT)	3000 Vac
Insulation voltage (input / ground)	1605 Vac
Insulation voltage (Output / ground)	500 Vac
Protection Class (EN/IEC 60529)	IP20
Reliability: MTBF IEC 61709	> 300.000 h
Pollution Degree Environment	2
Connection Terminal Blocks screw Type	2,5mm(24-14AWG)
Connection Terminal	IEC
Protection class	II
Dimensions (w-h-d) (Approx.)	70x91x57 mm
Weight (Approx.)	0.40 kg

Input Data	
Nominal Input Voltage (2 x Vac)	115 - 230 - 277
Input Voltage range (Vac)	90 - 305
Inrush Current (Vn - In nom. Load) I <sub>in</sub>	≤ 10 A ≤ 5 msec.
Frequency	47 ÷ 63 Hz
Input Current (115 - 230 Vac)	1 - 0.7 A
Internal fuse (not replaceable)	4 A
External Fuse (recommended) MCB curve B	6 A

General Output Data	
Output Voltage 24 Vdc	24 Vdc
Nominal current I <sub>n</sub> = I <sub>load</sub> < 40°C (In)	3 A ± 5%
Nominal current I <sub>n</sub> = I <sub>load</sub> > 40°C (In)	2.5 A ± 5%
Turn-On delay after applying mains voltage	1 sec. (max)
Start up with Strong Load (capacitive load)	Yes, Unlimited
Efficiency (at 50% of rated current)	≥ 90 %
Dissipation power load max (W)	6
Start from Battery only, without main	Push Button
Short-circuit protection	Yes
Over Load protection	Yes
Over Voltage Output protection	Yes (typ. 35 Vdc)
Overheating Thermal protection	Yes

Load Output 24 Vdc (jumper selection)	
Output voltage (at I <sub>n</sub> )	22 - 28.8 Vdc (30Vdc Ni-Cd)
Nominal Current I <sub>n</sub>	1.1 x In A ± 5%
Continuous current (without battery) I <sub>load</sub> = I <sub>n</sub>	2.5 A
Continuous current (With battery) I <sub>load</sub> = I <sub>n</sub> + I <sub>batt</sub>	2 x I <sub>n</sub>
Max. Output Load (Main with Battery) I <sub>load</sub> = I <sub>n</sub> + I <sub>batt</sub> (4 sec.)	3 x I <sub>n</sub> max. (A)
Max. current Output Load (Back Up) I <sub>load</sub> (4 sec.)	2 x I <sub>n</sub> max.
Push Button "Start from Battery without main"	Yes
Time Buffering: (switch output off without main input)	0.5; 2; 5; 10; 15; 20; 30; 45; 60; ∞

Battery Output	
Output Voltage Battery	22 - 28.8 Vdc
Fast Charge - Boost charge (25 °C) (at I <sub>n</sub> )	2.4 V/cell.
Max. Time Boost/Fast charge (Typ. at IN)	15 h
Min. Time Boost/Fast charge (Typ. at IN)	1 min.
Max. Time Bulk charge (Typ. at IN)	15 h
Min. Time Bulk charge (Typ. at IN)	1 min.
Trickle Charge: Depend on Battery type (V cell)	2.23; 2.25; 2.27; 2.3
Ni-Cd: Trickle - Boost charging V/cell (20 cell)	1.4V - 1.5V
Recovery Charge	2 - 16 V
End of charging Current (Bulk & Absorption charge)	6% of current limiting
Charging current max I <sub>batt</sub>	In ± 5%
Charging current limiting I <sub>chg</sub>	10 ÷ 100 % / I <sub>batt</sub>
Reverse battery protection	Yes
Sulfated battery check	Yes (by Jumper)
Detection of element in short circuit	Yes
Quiescent Current on the battery	≤ 5 mA
Charging Curve automatic: IUoU	4 stage
Fast Charge	Boost /Trickle
Threshold alarm Battery almost flat	20 - 21 Vdc batt
Protections against total discharge	19 - 20 Vdc batt

Signal Output (Open Collector)	
Main or Backup Power (Sink 20 mA max)	ON: 0 Vdc OFF: Vout (Alarm)
Fault Battery / System (Sink 20 mA max)	ON: 0 Vdc OFF: Vout (Alarm)
Rectifier Failure "Device" (Sink 20 mA max)	ON: 0 Vdc OFF: Vout (Alarm)

Signal Input	
Battery Start	Terminal Block
Temp. Comp. Battery (with external probe)	Push Button
Temp. Comp. Battery (with external probe)	RJ temp (RJ11)
Digital Input / Output	
Communication Protocol (Ethernet)	TCP/IP - SNMP
ADELbus	Can

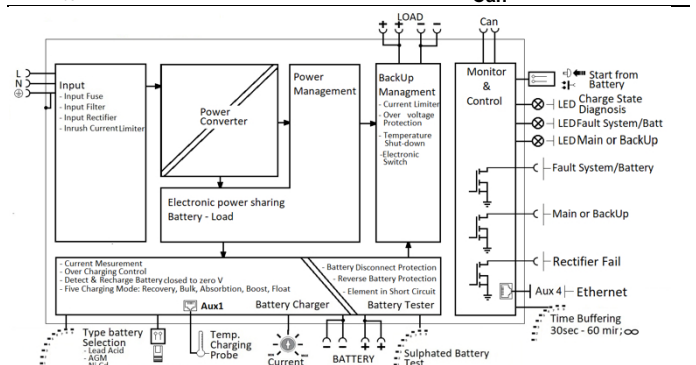

All specifications are subject to change without notice