

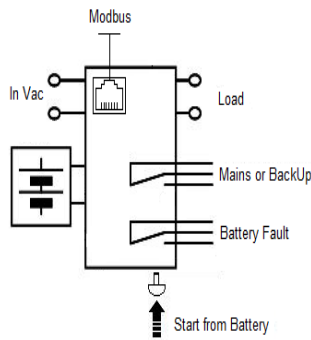

Your Power House
VP ELECTRONIQUE

EA-0420

VPI6012A



Input: Single-phase 115 - 230 - 277 Vac
Output Selectable Load: 12Vdc 5A
Output Battery charging: 12 Vdc 5A
Suited for the following battery types: Open Lead Acid, Sealed Lead Acid, lead Gel and Ni-Cd
Automatic diagnostic of battery status, Battery Life Test function (internal Battery Impedance)
Charging curve IUoU, constant voltage and current
Four charging levels: Boost, Absorption, Trickle, Recovery
Protected against short circuit and inverted polarity
Signal output: for battery Fault, Mains or Back-UP
Modbus RTU for all parameter battery and system
Ethernet TCP/IP
DIN rail and Wall mount

Technical features

Power Management: Thanks to the All In One units (DC-UPS), it will be possible to optimize power management. The available power is automatically allocated between load and battery, supplying power to the load is the first priority of the unit thus it is not necessary to double the power, because also the power going to the battery will go to the load if the load so requires. The maximum available current on the load output is 3 times the value of the device rated current In.

Battery Cater: it's the concept base on algorithms that implement rapid and automatic charging, four state of charge, battery charge optimization during time, flat batteries recovery and real time diagnostic during installation and operation. The Real Time Auto-diagnostic system, monitoring battery faults such as, battery Sulfated, elements in short circuit, accidental reverse polarity connection, disconnection of the battery, they can easily be detected and removed by help of Blink Code of Diagnosis Led; during the installation and after sell. The continuous monitoring of battery efficiency, reduces battery damage risk and allows a safe operation in permanent connection. Each device is suited for all battery types, by means of jumpers it is possible setting predefined curves for Open Lead Acid, Sealed Lead Acid, Gel, Ni-Cd(option). They are programmed for two charging levels, boost and trickle, but they can be changed to single charging level by the user. A rugged casing for DIN rail mounting, IP20 protection degree. They are extremely compact and cost-effective.

Interconnections: The 'platform' communication for devices allows the connection of all components in a simple but very powerful way. A protocol communication based on MODbus-RTU or CANbus technology. You can select any of the two buses depending on the application. It allows to communicate with all the accessories provided by and to develop an independent system for electrical continuity. At the same time, it allows monitoring and control all parameters in the system, even from the other side of the world, by means of application tools on the cloud.

allows you to implement very simple but sophisticated monitoring and control for your energy system and opens your mind to new ways to approach your applications.

Norms and Certifications

In Conformity to: IEC/EN 60335-2-29 Battery chargers; EN60950 / UL1950 Electrical safety; EN54-4 Fire Detection and fire alarm systems; 89/336/EEC EMC Directive; 2006/95/EC (Low Voltage); DIN41773 (Charging cycle); Emission : IEC 61000-6-3; Immunity: IEC 61000-6-2. CE.

Climatic Data

Ambient temperature (operation)	-25 ÷ +70°C
De Rating T ³ > 50°C	- 2.5%(In) / °C
Ambient temperature Storage	-40 ÷ +85°C
Humidity at 25 °C no condensation	95% to 25°C
Cooling	Auto convention

General Data

Insulation voltage (IN/OUT)	3000 Vac
Insulation voltage (input / ground)	1605 Vac
Insulation voltage (Output / ground)	500 Vac
Protection Class (EN/IEC 60529)	IP20
Reliability: MTBF IEC 61709	> 300.000 h
Pollution Degree Environment	2
Connection Terminal Blocks screw Type	2,5mm(24-14AWG)
Connection Terminal	IEC
Protection class	II
Dimensions (w-h-d) (Approx.)	70x91x57 mm
Weight (Approx.)	0.40 kg

Input Data

Nominal Input Voltage (2 x Vac)	115 - 230 - 277
Input Voltage range (Vac)	90 - 305
Inrush Current (Vn - In nom. Load) I ² t	≤ 10 A ≤ 5 msec.

Frequency	47 ÷ 63 Hz
Input Current (115 - 230 Vac)	1 - 0.7 A
Internal fuse (not replaceable)	4 A
External Fuse (recommended) MCB curve B	6 A

General Output Data

Output Voltage 12 Vdc	12 Vdc
Output Current I _n	5 A
Turn-On delay after applying mains voltage	1 sec. (max)
Start up with Strong Load (capacitive load)	Yes, Unlimited
Efficiency (at 50% of rated current)	≥ 90 %
Disipation power load max (W)	6
Continuous current (without battery) I _{load} = I _n	5 A
Continuous current (With battery) I _{load} = I _n + I _{batt}	2 x I _n
Max. Output Load (Main with Battery) I _{load} = I _n + I _{batt} (+sec.)	3 x I _n , max. (A)
Max. current Output Load (Back Up) I _{load} (+sec.)	2 x I _n , max.
Push Button or Remote Input Control (RTCONN cable)	Start From Battery Without Main
Time Buffering; min (switch output off without main input)	0.5;2;5;10;15; 20; 30; 45;60;∞

Short-circuit protection	Yes
Over Load protection	Yes
Over Voltage Output protection	Yes (typ. 35 Vdc)
Overheating Thermal protection	Yes

Load Output 12 Vdc (jumper selection)

Output voltage (at I _n)	11 - 14.4 Vdc
Nominal current I _n = I _{load} < 40°C (In)	5 A ± 5%
Nominal current I _n = I _{load} > 40°C (In)	5 A± 5%
Threshold alarm Battery almost flat	9 - 10 Vdc batt
Protections against total discharge	10 - 11 Vdc batt

Battery Output

Output Voltage Battery	Follow Out Load
Boost charge (25 °C) (at I _n)	2.4 V/cell.
Max. time Bust Charge	15 h
Min. time Bust Charge	1 min.
Jumper Configuration battery type (V cell)	2.23;2.25;2.27;2.3;
Ni-Cd (optional); when Trickle Charging mode	NiCd:1.5 (20 cell.)
Charging current max I _{batt}	In ± 5%
Charging current limiting I _{adj}	10 ÷ 100 % / I _{batt}
Reverse battery protection	Yes
Sulfated battery check	Yes (by Jumper)
Detection of element in short circuit	Yes
Quiescent Current on the battery	≤ 5 mA
Charging Curve automatic: IUoU	4 stage
Remote Input Control (RTCONN cable)	Boost /Trickle

Signal Output (free switch contacts)

Main or Backup Power	Yes
Low Battery	Yes
Fault Battery	Yes

Type of Signal Output Contact

Max. Current can be switched (EN60947.4.1):	
Max. DC1: 30 Vdc 1 A; AC1: 60 Vac 1A	Resistive load
Min.1mA at 5 Vdc	Min permissible load

Signal Input / Output (RJ45)

Temp. Comp. Battery (with external probe)	Yes (Aux 1)
Modbus	Yes..(Aux 2)
Ethernet TCP/IP	Yes