



EA-00416

1500W Programmable Digital Power Supply

VP -1500-HV series

Your Power House
VP ELECTRONIQUE

VP-1500

1500W Programmable Digital Power Supply



Features:

- Universal AC input / Full range (90~264Vac)
- Programmable output voltage and current (0~105%)
- Current sharing at parallel operation
- Constant current limit
- AUX POWER : +5.0V/1.0A
- Built-in OR'ing FETs
- Power OK signal (built -in isolation circuit)
- Remote on/off function
- Intelligent GUI to set and monitoring parameter
- Protection: OVP,OCP,OLP,OTP, Fan failure
- Support Parallel operation via CANBUS (built -in isolation circuit, A23, A24 Version)

Model Naming Rule: VP-1500-XX-①②③

VP : Product Series 1500 : Wattage XX : Output voltage ①②③ : can be A23, A24, C11 or D11

Hardware (Interface changeable):

A23 & A24 : RS-485 Support parallel connection with built-in communication isolation circuit

C11 : Single unit only

D11 : Ethernet

Communication protocol :

A23 : STD protocol (RS-485), and Meet PMBus

A24 : MODBUS & Meet PMBus

C11 : STD protocol (RS-485)

D11 : ARP, Device Search Utility (DSU), DHCP Client, IPv4, SNMP, TCP, UDP, ICMP

		VP-1500-120	VP-1500-150	VP-1500-250	VP-1500-400
Output	DC Voltage Rated	120V	150V	250V	400V
	Rated Current	12.5A	10.0A	6.0A	3.75A
	Current Range	0 ~ 12.5A	0 ~ 10.0A	0 ~ 6.0A	0 ~ 3.75A
	Voltage Range	0~105% vs. rated			
	Rated Power	1500W	1500W	1500W	1500W
	Ripple & Noise (Max.)	1200mVp-p	1500mVp-p	2500mVp-p	4000mVp-p
	Voltage Adj. Range	±5.0% Typical adjustment			
	Voltage Tolerance	±2.0% (rate output voltage of single unit)			
	Current Tolerance	±3.0% (rate output current of single unit)			
	Line Regulation	±1.0%			
	Load Regulation	±1.0%			
	Setup, Rise Time	1300ms, 200ms at full load (230V ac)			
	Hold Up Time (Typ.)	14ms / 230VAC at full load			
Input	Voltage Range (Note. 4)	90 ~ 264VAC, 250~370VDC *			
	Frequency Range	47 ~ 63Hz			
	Power Factor (Typ.)	0.95 / 230VAC, 0.99 / 115VAC at full load			
	Efficiency (Typ.)	92%			
	AC Current (Typ.)	18A / 115VAC, 9A / 230VAC			
	Inrush Current (Typ.)	30A / 115VAC, 45A / 230VAC (cold start)			
Leakage Current	≤ 3.5mA / 230VAC				

		VP-1500-120	VP-1500-150	VP-1500-250	VP-1500-400
Protection	Over Load	105% rated output power	Protection type: Constant current limit		
	Over Voltage	Programmable OVP, 120 ± 7% Vout.	Protection type: Latch-style (Recovery after reset AC power ON or inhibit)		
	Over Temperature	Detect on NTC, Protection type: Auto recovery after temperature goes down			
Function	Auxiliary Power	+5.0V / 1.0A			
	Remote ON / OFF Control	By external switch / communication			
	Power OK Signal	Open drain signal low when PSU turns on, Max. sink current: 20mA, Max. drain voltage: 40V			
	Output Voltage Trim	Adjustment of output voltage is between 0% ~ 105% of rated output			
	Output Current Trim	Adjustment of output current is between 0% ~ 105% of rated output			
	Parallel	Current sharing via CANBUS			
	Environment	Working Temp.	-25 ~ +60°C (Refer to load de-rating curve)		
Working Humidity		20 ~ 90% RH non-condensing			
Storage Temp. & Humidity		-40 ~ +85°C, 10 ~ 95% RH			
Temp. Coefficient		±0.02% / °C (0 ~ 50°C)			
Vibration		10 ~ 500Hz, 2G 10min. / 1cycle, period for 60min. each along X, Y, Z axes Compliance to IEC 68-2-6, IEC 68-2-64			
Safety & EMC	Safety Standards	UL 62368-1; EN 62368-1			
	Withstand Voltage (Note. 7)	I/P-O/P: 3KVAC (4242VDC), I/P-FG: 1.5KVAC (2121VDC), O/P-FG: 0.5KVAC (707VDC)			
	Isolation Resistance	I/P-O/P, I/P-FG, O/P-FG: 100M Ohms / 500VDC			
	EMI Conduction & Radiation	EN 55032; EN 61204-3; EN 61000-6-3			
	Power Harmonic & Voltage Fluctuation and Flicker	EN 61000-3-2; EN 61000-3-3			
	EMS Immunity (Note. 6)	EN55035: 2017 / A11: 2020 ; IEC 61000-4-2,3,4,5,6,8,11			
	Others	Cooling	Load and temperature control fan		
Dimension (WxHxD)		127.8 x 63.9 x 296.3 mm / 5.03 x 2.52 x 11.67 inch			
Packing		2.6kg; 6pcs / 16.6kg / 1.86 CUFT			

*Note:

1. All parameters NOT specially mentioned are measured at 230VAC input, rated load and 25°C of ambient temperature.
2. Ripple & noise are measured at 20MHz of bandwidth by using a 12" twisted pair-wire terminated with a 0.1uF & 47uF parallel capacitor.
3. Tolerance: includes setup time tolerance, line regulation and load regulation.
4. De-rating may apply in low input voltage. Please check the de-rating curve for more details.
5. In parallel connection, only one unit will operate if the total output load is less than 10% of the rated power.
6. The power supply is considered a component which will be installed into a final equipment. The final equipment must be re-confirmed that it still meets EMC directives.
7. This test is done without enclosure: I/P-O/P 4242VDC. If with enclosure: I/P-O/P 2121VDC, I/P-FG: 2121VDC, O/P-FG: 707VDC

■ De-rating Curve

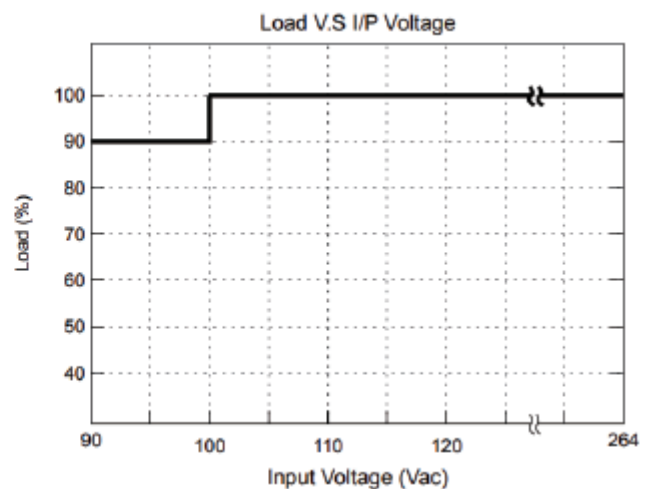
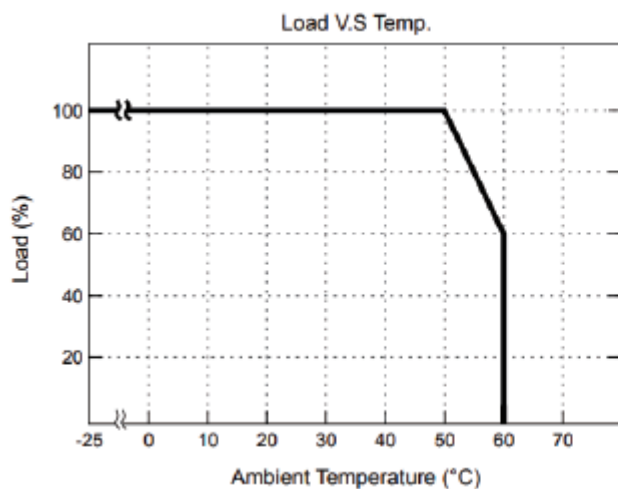

■ REMOTE ON/OFF

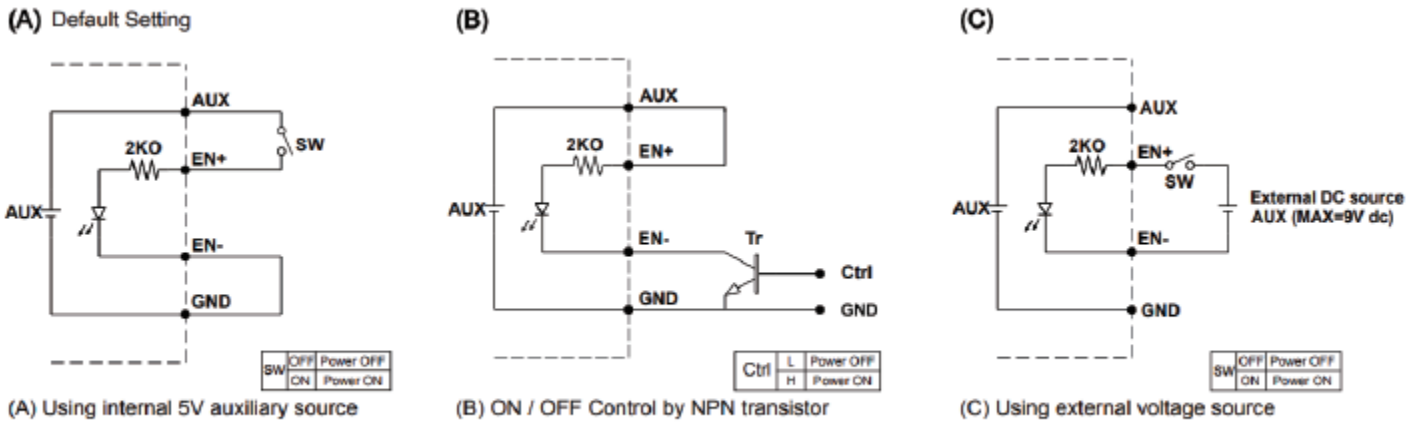

GND shown in above diagram is referring to the GND of the interchangeable interface card, not the Grounding from main power(NEG-).

■ Power OK Signal & Auxiliary Power Setting

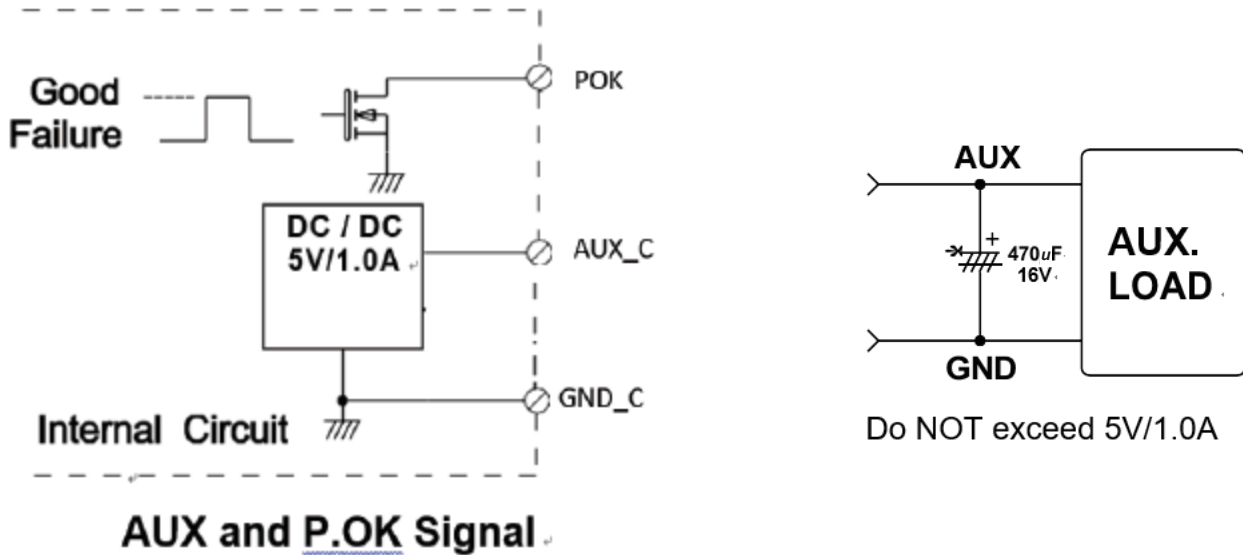

Open drain signal low when PSU turns on, Max. P.OK sink current: 20mA, Max. drain voltage: 40V











A23 and A24

The grounding of "AUX" power and P.OK signal should be connected to GND_C port. GND_C & VO- are used for isolation with different voltage level.

C-11

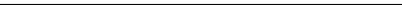
GND shown in above diagram is referring to the GND of the VP-1500 Chassis, not the Grounding from the main power(NEG-)

■ Function LED

LED	LED Signal	Status
Solid(Green)		Power OK (Local mode)
Solid(Orange)		Power OK (Remote mode)
Slow Blink(Green)		Power Standby (Local mode)
Slow Blink(Orange)		Power Standby (Remote mode)
Fast Blink(Red)		Over Voltage Protection (OVP)
Solid(Red)		Over Load Protection (OLP)
Slow Blink(Red)		Over Temperature Protection (OTP)
Intermittent Blink(Red)		Fan Failure
Interlace Blink (Red)		Power Failure
Slow Blink (Red)		AC Failure

■ Interface card (Changeable)

1. A23&A24 (Support Parallel Connection)

2. C11 (Single unit)

3. D11 (Ethernet)

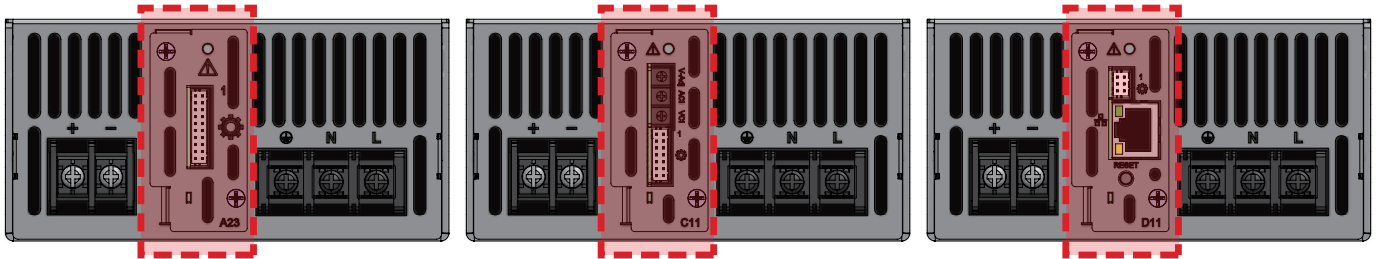

PIN Function Description:

1. A23 & A24 (Support Parallel Connection)

Pin No.	Function	Description	Pin No.	Function	Description	Mating Housing / Contact	
1	X	Reserve	2	X	Reserve	JST PHDR-20VS or equivalent	JST SPHD-002T-P0.5 or equivalent
3	X	Reserve	4	X	Reserve		
5	EN+	Inhibit ON/OFF (+)	6	AUX	5V / 1A Auxiliary power		
7	EN-	Inhibit ON/OFF (-)	8	GND_C	Communication Ground		
9	H_TERM	CAN Termination	10	L_TERM	CAN Termination		
11	CANH	Dedicated in parallel (CAN BUS High-level)	12	CANL	Dedicated in parallel (CAN BUS Low-level)		
13	SCL	Serial Clock used in the I ² C interface	14	SDA	Serial Data used in the I ² C interface		
15	POK	Power OK (40V / 20mA / <0.5W Open collector)	16	GND_C	Communication Ground		
17	RS485-A	Driver Output / Receiver Input Non-inverting	18	RS485-B	Driver Output / Receiver Input Inverting		
19	AUX_C	5V / 1A Auxiliary power	20	GND_C	Communication Ground		

Installation Instruction

1. Mounting Directions

1-1 Recommended standard mounting methods:

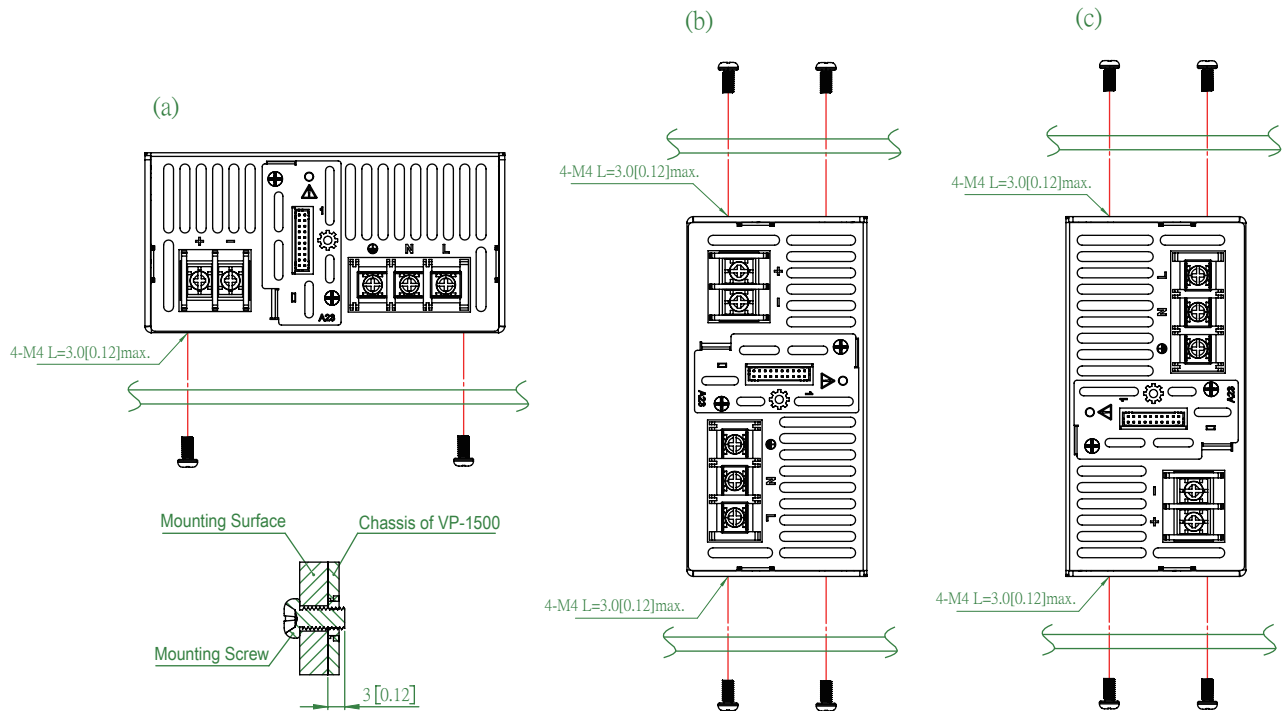

Recommended screw length is measured from the power supply surface

2. Mounting Method

2-1 There are ventilating holes on the front and back side panels, do not obstruct; allow 50mm at least for air flow.

2-2 Recommended the torque of mounting screw: M4 screw: 1.27Nm (13.0kgf cm)

