

**KEY FEATURES**

- Switching Power Module for PCB Mountable
- Universal Input: 90-264 VAC
- Full Brick Size with Base Plate
- Over Current Protection
- Over Voltage Protection
- Over Temperature Protection
- Short Circuit Protection
- Remote Sense
- 3-Year Product Warranty



**ELECTRICAL SPECIFICATIONS**

1. All specifications valid at normal input voltage, full load and +25°C after warm-up time unless otherwise stated.
2. Please connection Fig 1.1 for standard use.
3. Refer to instruction manual for measuring method of electric characteristics.
4. Ripple & Noise are measured at 20MHz of bandwidth with 0.1uF & 47uF parallel capacitor.

Model No.	VPBR300-12S	VPBR300-24S	VPBR300-28S	VPBR300-48S	
Max Output Wattage (W)	300W				
Input	Voltage	90-264 VAC			
	Frequency (Hz)	50/60 Hz (47-63 Hz)			
	Current (Full load)	<4.0 A (100 VAC) / <2.0 A max. (200 VAC)			
	Inrush Current (<2ms)	Limited by external resistance			
	Leakage Current	< 0.75 mA max.			
	Power Factor (typ.)	PF>0.95 (100 VAC) / PF>0.9 (200 VAC) at Full Load			
Output	Voltage (V.DC.)	12V	24V	28V	48V
	Trim	±5% Output Voltage			
	Voltage Accuracy	±2%			
	Current (A) (max.)	25	12.5	11	6.25
	Line Regulation (LL-HL) (typ.)	±1%			
	Load Regulation (5-100%) (typ.)	±1%			
	Minimum Load	0%			
	Ripple & Noise (max.)	150mV	200mV	200mV	300mV
	Efficiency (at 230VAC)	90%	90.5%	90.5%	91%
	Remote Sensing	Provided			
	ENA	Open collector (10mA sink current), Low (on) when output is present.			
	Hold-up Time	Limited by external capacitor			
Protection	Over Current Protection	Auto recovery			
	Over Voltage Protection	Auto recovery			
	Over Temperature Protection	Auto recovery			
	Short Circuit Protection	Auto recovery, Hiccup mode			
Isolation	Input-Output (V.AC)	3000V			
	Input-FG (V.AC)	2000V			
	Output-FG (V.AC)	500V			
Environment	Operating Temperature	-40°C...+100°C (On Aluminum Base Plate)			
	Storage Temperature	-40°C...+100°C			
	Temperature Coefficient	±0.05%/°C ( 0~50°C )			
	Humidity	20~95% RH (Non condensing)			
	MTBF	>250,000 h @ 25°C (MIL-HDBK-217F, Notice 1)			
Physical	Vibration	10~500Hz, 2G 10min./1cycle, 60min. each along X, Y, Z axes.			
	Dimensions (L x W x H)	4.62 x 2.42 x 0.52 Inches ( 117.3 x 61.5 x 13.2 mm ) max.			
	Weight	111 g			
Safety	Cooling Method	Conduction cooling			
	Agency Approvals	UL60950-1, EN90950-1			
Other	Cooling Method	Cooling Method			

CONNECTION FOR STANDARD USE

- (1.) To use the VPBR300 series, external parts should be connected as shown in Fig 1.1.
- (2.) The VPBR300 series should be conduction-cooled. Use a heatsink or fan to dissipate heat.

Fig 1.1

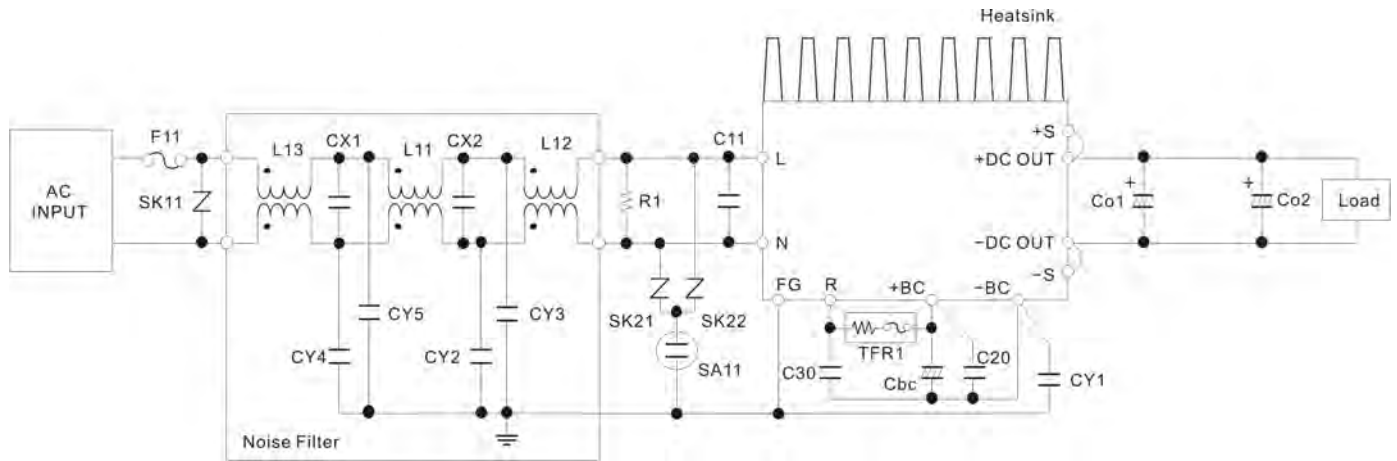
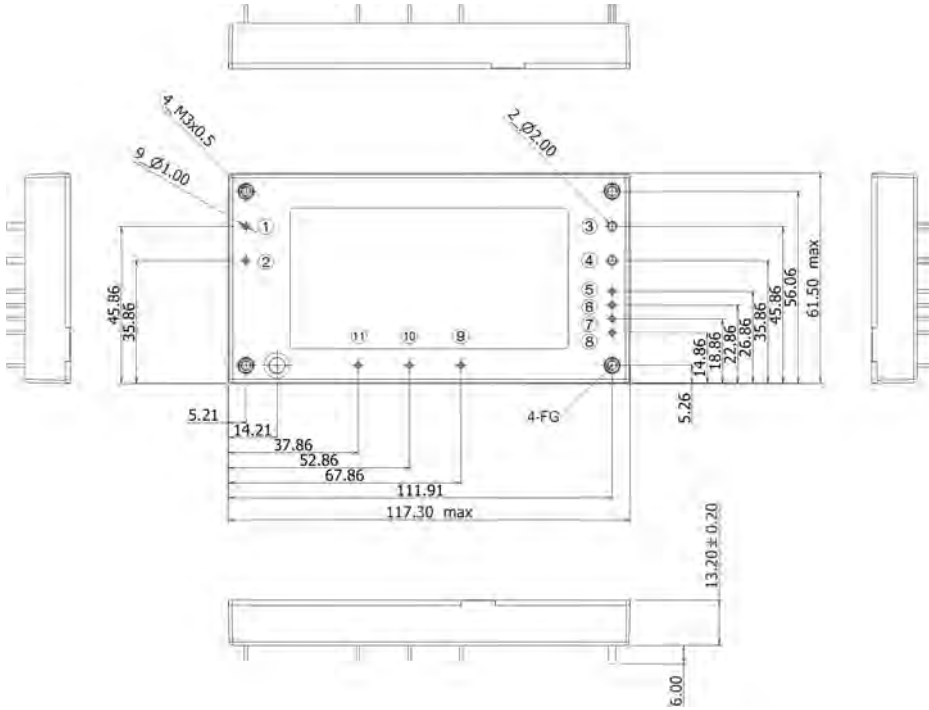

Table 1.1 (Parts name.)

No.	Symbol	Item	Rating	Remark	
1	F11	Input fuse	AC250V / 10A	-	
2	C11	Input capacitor	AC275V / 1uF	Class X1 or X2	
3	CY1	Y capacitor	AC250V / 1000pF	Class Y1	
4	L11	Line Filter	Min. 9mH	-	
5	L12		Min. 12mH	-	
6	L13		Min. 100uH	-	
7	CX1	Noise filter	AC275V / 0.68uF	Class X1 or X2	
8	CX2		AC275V / 1uF	Class X1 or X2	
9	CY2, CY3	Y capacitor	AC250V / 2200pF	Class Y1 or Y2	
10	CY4, CY5		AC250V / 1000pF	Class Y1 or Y2	
11	Co1	Output pi filter	12S	DC16V / 1500uF x2	Conductive Polymer
			24S, 28S	DC35V / 1000uF x3	Electrolytic capacitor
			48S	DC63V / 390uF x3	Electrolytic capacitor
12	Co2		12S	DC16V / 2200uF x2	Electrolytic capacitor
			24S, 28S	NC	Electrolytic capacitor
			48S	NC	Electrolytic capacitor
13	Cbc	Smoothing capacitor for boost voltage	DC450V / 470uF	Electrolytic capacitor	
14	C20,C30	Capacitor for boost voltage	DC450V / 0.68uF x2 (parallel)	Film capacitor	
15	TFR1	Inrush current limiting resistor	10Ω	Thermal fuse build-in resistor	
16	R1	Discharging resistor	470K Ω	1/4W resistor	
17	SK21 / SK22	Varistor	NC	-	
18	SA11	Surge absorber	NC	-	
19	SK11	Varistor	620V	300Vac / 3500A (8/20μS)	

- ⊙ Parts name are shown in Table 1.1 as reference.
- ⊙ External parts should be changed according to the ambient temperature, and input and output conditions. For details, refer to the selection method of individual parts.

**MECHANICAL DIMENSIONS (External View )**



PIN#	Φ	Single
1	1.0±0.1%mm	AC IN (L)
2	1.0±0.1%mm	AC IN (N)
3	2.0±0.2%mm	-DC OUT
4	2.0±0.2%mm	+DC OUT
5	1.0±0.1%mm	-S
6	1.0±0.1%mm	+S
7	1.0±0.1%mm	TRIM
8	1.0±0.1%mm	ENA
9	1.0±0.1%mm	-BC
10	1.0±0.1%mm	+BC
11	1.0±0.1%mm	R

**DERATING**

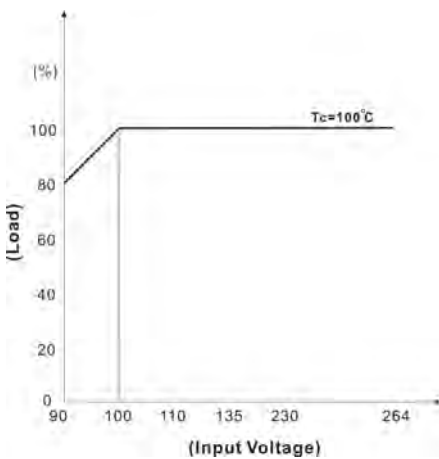
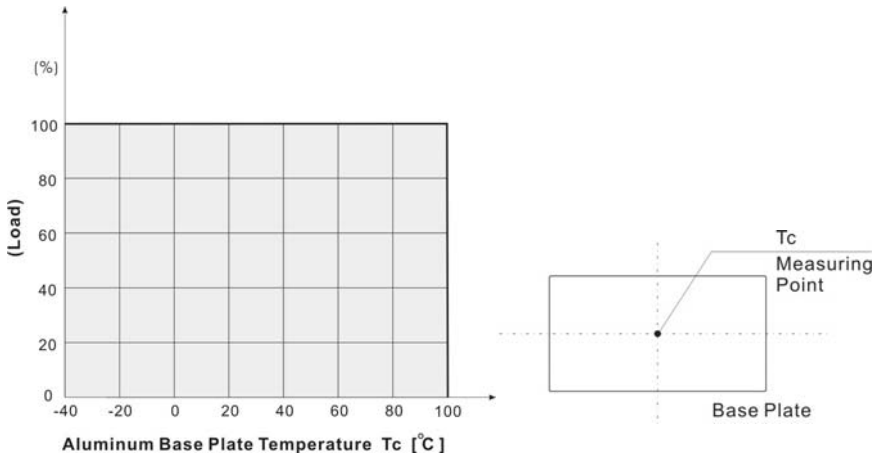

We reserve the right to make alterations in the product materials and specifications without prior notification and consent to improve reliability, function or design or otherwise.