

Úæ ^ÁĠ

- FLYBACK TRANSFORMERS RANGE
- TRANSFORMERS/CONTROL CIRCUITS CROSS REFERENCE LIST
- 1 TO 9 W EE 16 74090 – 74091 – 74092 – 74093 – 74094 – 74095
- 1 TO 6 W EE 16 74000 – 74001 – 74002 – 74003
- 6 TO 12 W EE 16 74010 – 74014 – 74015
- 10 TO 18 W EL 19 74020 – 74021 – 74023
- 12 TO 24 W EF 20 74080 – 74081 – 74082
- 15 TO 30 W EE 25 74030 – 74032
- 35 TO 60 W ETD 29 74040
- 35 TO 60 W ERL 28 74043
- 60 TO 90 W ETD 34 74050
- 70 TO 140 W ETD 39 74060
- 120 TO 180 W ETD 44 74070



COMMON MODE CHOKES FOR EMI SUPPRESSION

Úæ ^ÁĠĠ

TOROIDAL CHOKES

Úæ ^ÁĠĠ

- DIMMER CHOKES FOR EMI SUPPRESSION

DRUM CORE CHOKES

Úæ ^ÁĠĠ

CURRENT TRANSFORMERS RANGE

Úæ ^ÁĠĠ

- FOR MAINS AC CURRENT MEASUREMENT 50 TO 400 HZ
- FOR SWITCH MODE POWER SUPPLIES 20 TO 150 KHZ

PULSE TRANSFORMERS RANGE

Úæ ^ÁĠĠ

- FOR MOSFET OR IGBT CONTROL, SCR TRIGGERING, DC/DC CONVERSION

POWER LINE COMMUNICATION COUPLING TRANSFORMERS

Úæ ^ÁĠĠ F



FLYBACK TRANSFORMERS RANGE for switch mode power supplies

MYRRA Part N°	CORE SIZE	Max. Output Power	Outputs				
		Watts	Vdc nominal voltage				
74000	E16	5w	5v	12v			
74001	E16	6w	5v				
74002	E16	6w	12v				
74003	E16	5w	3.3v	5v			
74010	E16	12w	5v	12v			
74014	E16	12w	24v	24v			
74015	E16	12w	5v	15v	24v		
74020	EL19	18w	5v	12v			
74021	EL19	18w	5v	12v			
74023	EL19	16w	3.3v	5v	12v	18v	30v
74030	E25	30w	5v	12v	12v		
74032	E25	35w	24v				
74040	ETD29	60w	5v	12v	5v	12v	
74043	ERL28	60w	3.3v	5v	12v	18v	30v
74050	ETD34	90w	5v	12v	5v	12v	
74060	ETD39	140w	5v	12v	5v	12v	
74070	ETD44	180w	5v	12v	5v	12v	
74080	EF20	24w	12v	12v			
74081	EF20	20w	3.3v	5v	12v		
74082	EF20	20w	5v	5v			
74090	E16	1.5w	5v				
74091	E16	1.5w	12v				
74092	E16	3.1w	5v				
74093	E16	3.1w	12v				
74094	E16	9w	5v				
74095	E16	9w	12v				

Note : "5 volts" outputs can generally be used for 3.3 to 6volts; "12 volts" outputs can be used for 9 to 16volts.
See detailed characteristics.

G

TRANSFORMER / CONTROL CIRCUITS CROSS-REFERENCE LIST

IC Manufacturer	IC reference	Transformer reference	Power
ST Microelectronics	VIPer100A	74050	80w
ST Microelectronics	VIPer100A	74060	120w
ST Microelectronics	VIPer20	74000	4w
ST Microelectronics	VIPer20	74001	6w
ST Microelectronics	VIPer20	74002	6w
ST Microelectronics	VIPer20	74003	6w
ST Microelectronics	VIPer20	74010	10w
ST Microelectronics	VIPer20	74020	12w
ST Microelectronics	VIPer50	74020	16w
ST Microelectronics	VIPer50	74021	13w
ST Microelectronics	VIPer50	74030	30w
ST Microelectronics	VIPer50	74040	45w
Power Integrations	TNY253	74090	1.5w
Power Integrations	TNY253	74091	1.5w
Power Integrations	TNY254	74092	3.1w
Power Integrations	TNY254	74093	3.1w
Power Integrations	TNY255	74094	4.2w
Power Integrations	TNY255	74095	5w
Power Integrations	TNY264	74094	5w
Power Integrations	TNY264	74095	5w
Power Integrations	TNY266	74014	12w
Power Integrations	TNY266	74015	10w
Power Integrations	TNY266	74094	9w
Power Integrations	TNY266	74095	9w
Power Integrations	TNY267	74010	12w
Power Integrations	TNY268	74020	15w
Power Integrations	TNY268	74082	17w
Power Integrations	TOP242P	74000	5w
Power Integrations	TOP242P	74001	6w
Power Integrations	TOP242P	74002	6w
Power Integrations	TOP242P	74003	5w
Power Integrations	TOP242P	74010	12w
Power Integrations	TOP242P	74014	12w
Power Integrations	TOP242P	74015	12w
Power Integrations	TOP243P	74020	18w
Power Integrations	TOP243P	74023	16w
Power Integrations	TOP243P	74080	24w
Power Integrations	TOP243P	74081	20w
Power Integrations	TOP243P	74082	20w
Power Integrations	TOP243Y	74021	18w
Power Integrations	TOP244P	74030	30w

IC Manufacturer	IC reference	Transformer reference	Power
Power Integrations	TOP244P	74032	25w
Power Integrations	TOP244Y	74030	25w
Power Integrations	TOP245Y	74040	60w
Power Integrations	TOP246Y	74043	60w
Power Integrations	TOP246Y	74050	90w
Power Integrations	TOP247Y	74060	140w
Power Integrations	TOP248Y	74070	180w
Power Integrations	TOP249Y	74070	120w
Infineon	TDA16831	74001	6w
Infineon	TDA16831	74002	6w
Infineon	TDA16831	74003	6w
Infineon	TDA16831	74010	10w
Infineon	TDA16831	74021	10w
Infineon	TDA16832	74020	16w
Infineon	TDA16832	74030	30w
Infineon	TDA16834	74040	35w
Infineon	TDA16834	74040	45w
Infineon	TDA16834	74050	80w
Infineon	TDA16836	74050	60w
Infineon	TDA16836	74060	70w
Infineon	TDA16836	74060	120w
Infineon	TDA16837	74070	160w
ON Semiconductors	MC33369	74001	6w
ON Semiconductors	MC33369	74002	6w
ON Semiconductors	MC33369	74003	6w
ON Semiconductors	MC33369	74010	10w
ON Semiconductors	MC33370	74020	16w
ON Semiconductors	MC33370	74021	13w
ON Semiconductors	MC33371	74030	30w
ON Semiconductors	MC33372	74040	45w
ON Semiconductors	MC33373	74050	80w
ON Semiconductors	MC33374	74060	120w
Philips	TEA1566	74070	120w
Fairchild	KA5H0165RN	74010	10w
Fairchild	KA5L0165R	74010	7w
Fairchild	KA1H0265R	74030	22w
Fairchild	KA1H0565R	74060	70w
Fairchild	KA2S0965	74070	160w

**TRANSFORMER
FOR TINYSWITCH**

SIZE E16 • SINGLE OUTPUT : 5 or 12v

- Primary / Secondary Insulation $\geq 4000V$
- Creepage distance Primary / Secondary $\geq 6mm$
- Ambient temperature $< 85^{\circ}C$
- Construction conforms to IEC950, IEC335, IEC61558 for reinforced insulation
- Exclusively uses UL94-V0 listed materials

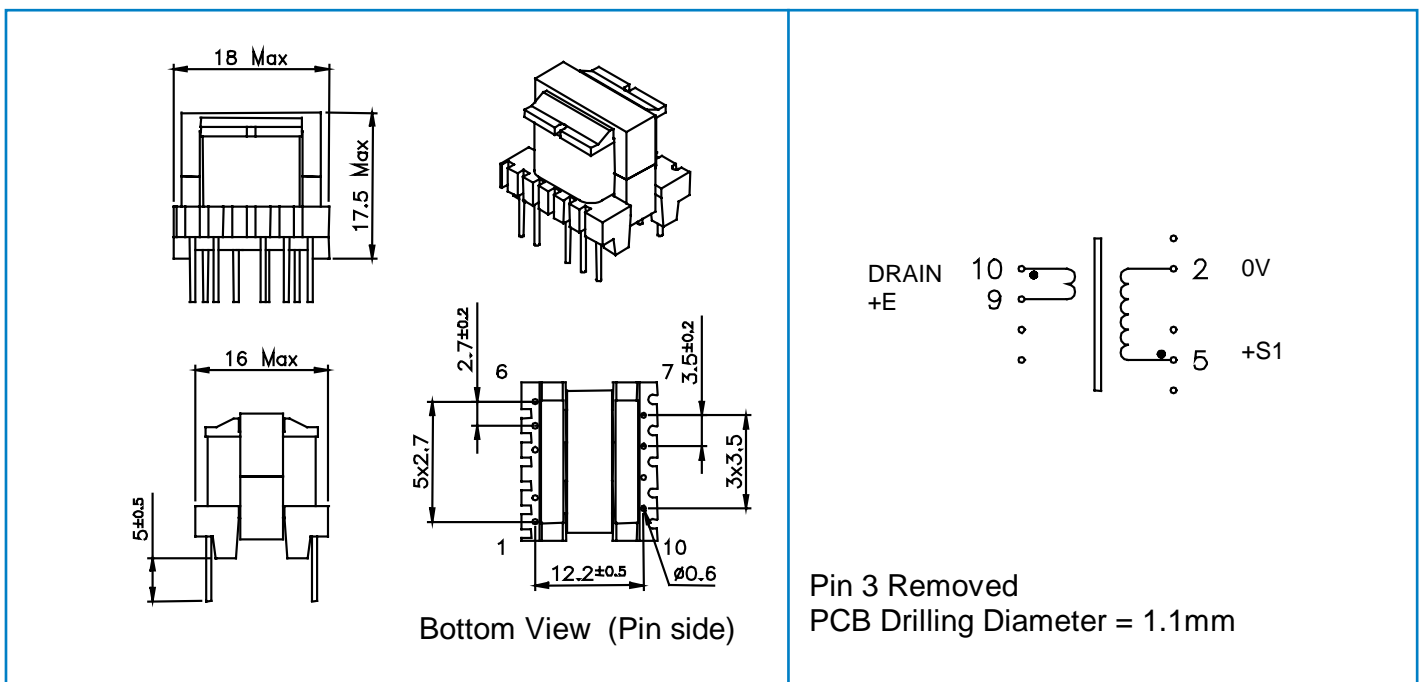

MYRRA P / N	Output Power maximum	Windings					
			Pins	Turns	Voltage	Current maximum	Inductance (+/-10%)
74090	1.5 w	Pri	10 - 9	228	50 - 95 (VOR)	0.28 Apeak	6000µH
		S1	5 - 2	16	3.3 - 6 Vdc	0.4 Adc	
74091	1.5 w	Pri	10 - 9	228	65 - 130 (VOR)	0.28 Apeak	6000µH
		S1	5 - 2	28	7.5 - 15 Vdc	0.2 Adc	

Examples of application with Integrated Circuits :

MYRRA P / N	Control IC Manufacturer	Control IC P / N	Input voltage	Power	Frequency
74090	Power Integrations	TNY253	85 - 265Vrms	1.5w	44kHz
74091	Power Integrations	TNY253	85 - 265Vrms	1.5w	44kHz

SIZE E16 • SINGLE OUTPUT : 5 or 12v

**TRANSFORMER
FOR TINYSWITCH**

- Primary / Secondary Insulation $\geq 4000V$
- Creepage distance Primary / Secondary $\geq 6mm$
- Ambient temperature $< 70^{\circ}C$
- Construction conforms to IEC950, IEC335, IEC61558 for reinforced insulation
- Exclusively uses UL94-V0 listed materials

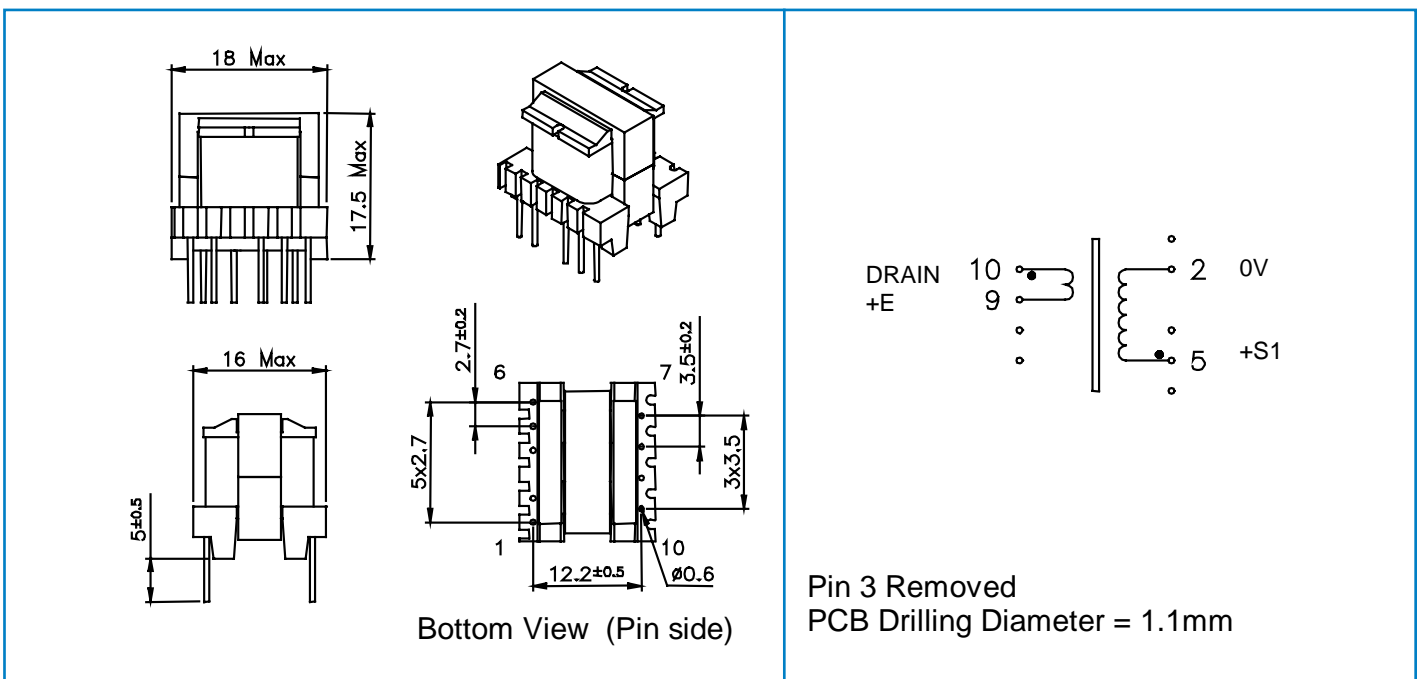

MYRRA P / N	Output Power maximum	Windings					
			Pins	Turns	Voltage	Current maximum	Inductance (+/-10%)
74092	3.1 w	Pri	10 – 9	191	55 – 100 (VOR)	0.34 Apeak	4200μH
		S1	5 – 2	13	3.3 – 6 Vdc	0.9 Adc	
74093	3.1 w	Pri	10 – 9	191	65 – 125 (VOR)	0.34 Apeak	4200μH
		S1	5 – 2	24	7.5 – 15 Vdc	0.4 Adc	

Examples of application with Integrated Circuits :

MYRRA P / N	Control IC Manufacturer	Control IC P / N	Input voltage	Power	Frequency
74092	Power Integrations	TNY254	85 - 265Vrms	3.1w	44kHz
74093	Power Integrations	TNY254	85 - 265Vrms	3.1w	44kHz

SIZE E16 • SINGLE OUTPUT : 5 or 12v

- Primary / Secondary Insulation $\geq 4000V$
- Creepage distance Primary / Secondary $\geq 6mm$
- Ambient temperature $< 60^{\circ}C$
- Construction conforms to IEC950, IEC335, IEC61558 for reinforced insulation
- Exclusively uses UL94-V0 listed materials

**TRANSFORMER
FOR TINYSWITCH**

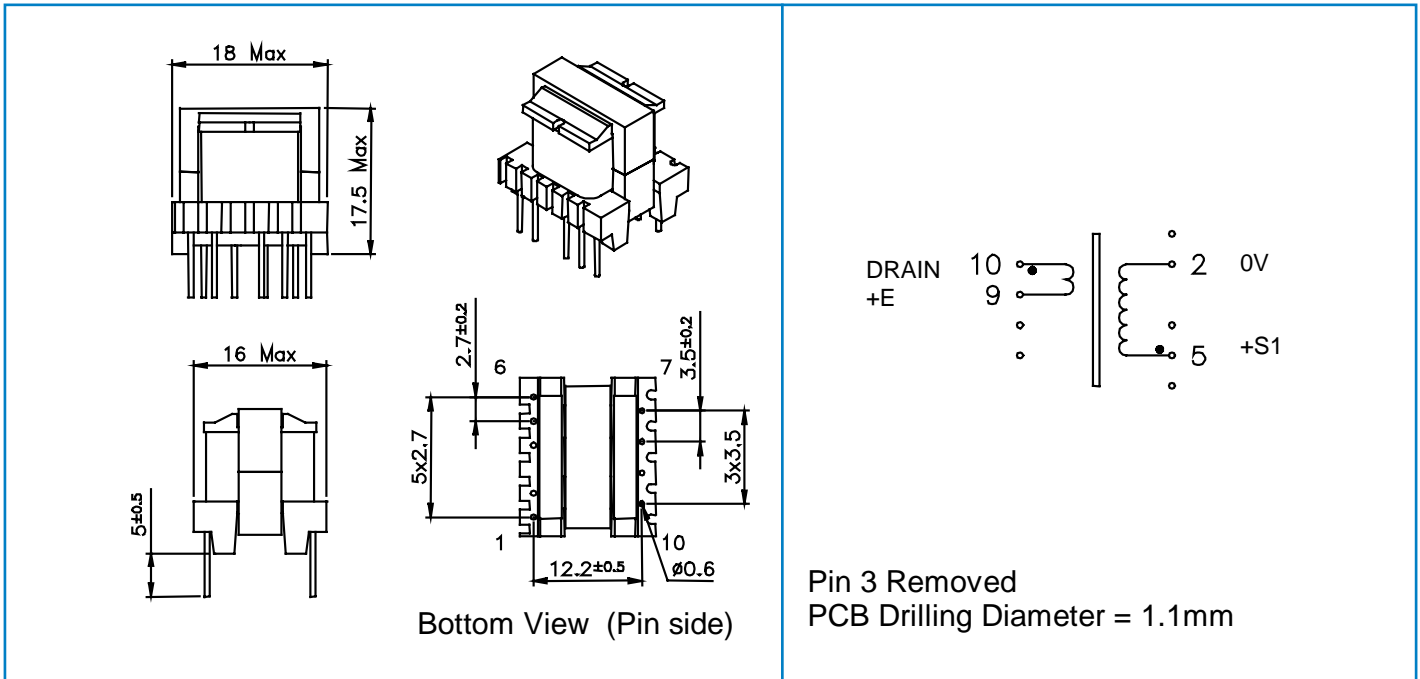

Bottom View (Pin side)

Pin 3 Removed
PCB Drilling Diameter = 1.1mm

MYRRA P / N	Output Power maximum	Windings					
			Pins	Turns	Voltage	Current maximum	Inductance (+/-10%)
74094	9 w	Pri	10 - 9	135	55 - 100 (VOR)	0.48 Apeak	2100µH
		S1	5 - 2	9	3.3 - 6 Vdc	1.5 Adc	
74095	9 w	Pri	10 - 9	135	65 - 125 (VOR)	0.48 Apeak	2100µH
		S1	5 - 2	17	7.5 - 15 Vdc	0.9 Adc	

Examples of application with Integrated Circuits :

MYRRA P / N	Control IC Manufacturer	Control IC P / N	Input voltage	Power	Frequency
74094	Power Integrations	TNY255	85 - 265Vrms	4.2w	44kHz
	Power Integrations	TNY264	85 - 265Vrms	5w	132kHz
	Power Integrations	TNY266	85 - 265Vrms	9w	132kHz
74095	Power Integrations	TNY255	85 - 265Vrms	5w	44kHz
	Power Integrations	TNY264	85 - 265Vrms	5w	132kHz
	Power Integrations	TNY266	85 - 265Vrms	9w	132kHz



SIZE E16 • 2 OUTPUTS : 5 & 12v

- Primary / Secondary Insulation $\geq 4000V$
- Primary / Auxiliary Insulation $\geq 1500V$
- Creepage distance Primary / Secondary $\geq 6mm$
- Ambient temperature $< 70^{\circ}C$
- Construction conforms to IEC950, IEC335, IEC61558 for reinforced insulation
- Exclusively uses UL94-V0 listed materials



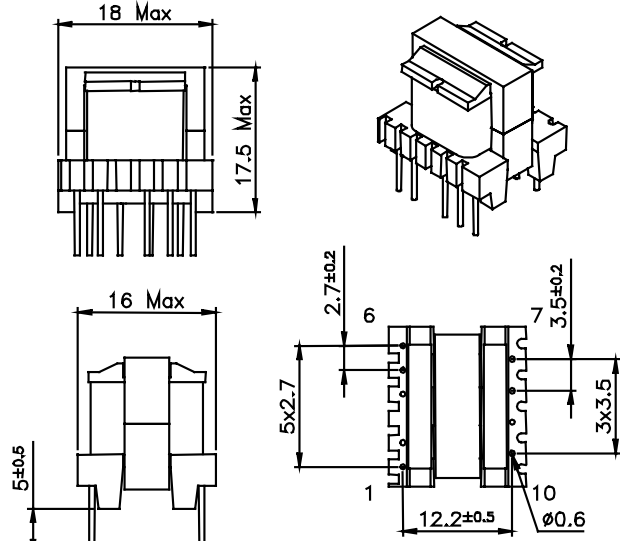

Bottom View (Pin side)

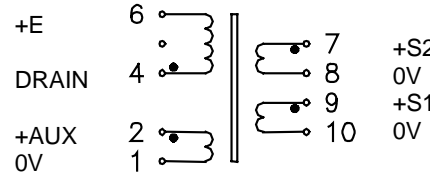

74000

PIN 3 Removed
PCB Drilling Diameter = 1.1mm

MYRRA P / N	Output Power maximum	Windings					
			Pins	Turns	Voltage	Current maximum	Inductance (+/-10%)
74000	5 w	Pri	4 - 6	138	62 - 130 (VOR)	0.27 Apeak	3900µH
		Aux	2 - 1	16	7 - 14 Vdc	0.1 Adc	
		S1	9 - 10	8	3.3 - 7 Vdc	1.2 Adc	
		S2	7 - 8	19	8 - 17 Vdc	0.4 Adc	

Examples of application with Integrated Circuits :

MYRRA P / N	Control IC Manufacturer	Control IC P / N	Input voltage	Power	Frequency
74000	Power Integrations ST Microelectronics	TOP242P	85 - 265Vrms	5w	132kHz
		Viper20	85 - 265Vrms	4w	70kHz

FLYBACK TRANSFORMER



SIZE E16 • SINGLE OUTPUT : 5 or 12v

- Primary / Secondary Insulation $\geq 4000V$
- Primary / Auxiliary Insulation $\geq 1500V$
- Creepage distance Primary / Secondary $\geq 6mm$
- Ambient temperature $< 60^{\circ}C$
- Construction conforms to IEC950, IEC335, IEC61558 for reinforced insulation
- Exclusively uses UL94-V0 listed materials

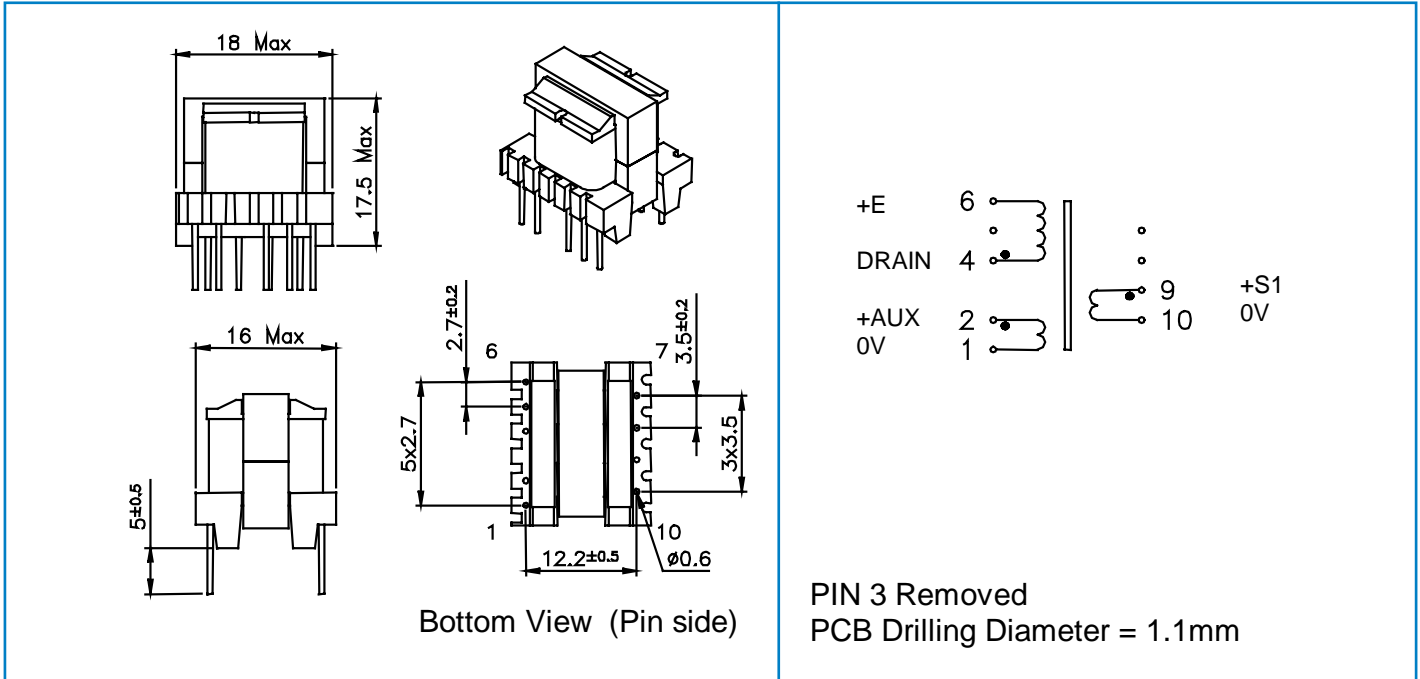

MYRRA P / N	Output Power maximum	Windings					
			Pins	Turns	Voltage	Current maximum	Inductance (+/-10%)
74001	6 w	Pri	4 - 6	138	60 – 120 (VOR)	0.35 Apeak	3000µH
		Aux	2 - 1	20	8 – 16 Vdc	0.1 Adc	
		S1	9 - 10	8	3 – 6 Vdc	1.2 Adc	
74002	6 w	Pri	4 - 6	150	60 – 120 (VOR)	0.38 Apeak	3000µH
		Aux	2 - 1	22	8.5 – 17 Vdc	0.1 Adc	
		S1	9 - 10	24	9 – 18 Vdc	0.5 Adc	

Examples of application with Integrated Circuits :

MYRRA P / N	Control IC Manufacturer	Control IC P / N	Input voltage	Power	Frequency
74001	Power Integrations	TOP242P	85 - 265Vrms	6w	132kHz
	ST Microelectronics	VIPer20	85 - 265Vrms	6w	70kHz
	ST Microelectronics	VIPer20	85 - 265Vrms	3w	40kHz
	Motorola	MC33369	85 - 265Vrms	6w	100kHz
	Infineon	TDA16831	185 - 265Vrms	6w	100kHz
74002	Power Integrations	TOP242P	85 - 265Vrms	6w	132kHz
	ST Microelectronics	VIPer20	85 - 265Vrms	6w	70kHz
	ST Microelectronics	VIPer20	85 - 265Vrms	3w	40kHz
	Motorola	MC33369	85 - 265Vrms	6w	100kHz
	Infineon	TDA16831	185 - 265Vrms	6w	100kHz

SIZE E16 • DUAL OUTPUT : 3.3 + 5v

- Primary / Secondary Insulation $\geq 4000V$
- Primary / Auxiliary Insulation $\geq 1500V$
- Creepage distance Primary / Secondary $\geq 6mm$
- Ambient temperature $< 60^{\circ}C$
- Construction conforms to IEC950, IEC335, IEC61558 for reinforced insulation
- Exclusively uses UL94-V0 listed materials

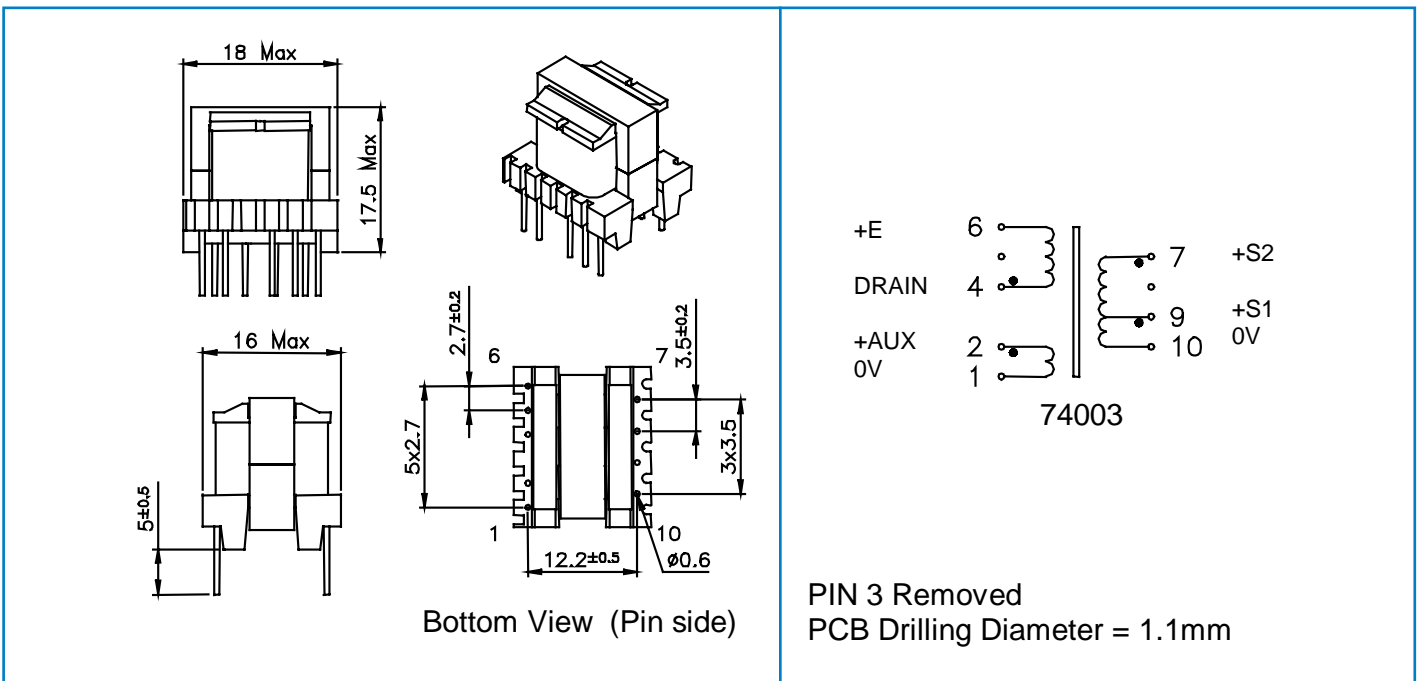

MYRRA P / N	Output Power maximum	Windings					
			Pins	Turns	Voltage	Current maximum	Inductance (+/-10%)
74003	6 w	Pri	4 - 6	120	55 - 115 (VOR)	0.3 Apeak	3000µH
		Aux	2 - 1	17	8 - 16 Vdc	0.1 Adc	
		S1	9 - 10	5	2 - 4 Vdc	1.8 Adc	
		S2	7 - 10	7	3 - 6 Vdc	1.2 Adc	

Examples of application with Integrated Circuits :

MYRRA P / N	Control IC Manufacturer	Control IC P / N	Input voltage	Power	Frequency
74003	Power Integrations	TOP242P	85 - 265Vrms	5w	132kHz
	ST Microelectronics	VIPer20	85 - 265Vrms	6w	70kHz
	ST Microelectronics	VIPer20	85 - 265Vrms	3w	40kHz
	Motorola	MC33369	85 - 265Vrms	6w	100kHz
	Infineon	TDA16831	185 - 265Vrms	6w	100kHz

**FLYBACK
TRANSFORMER**



SIZE E16 • 2 OUTPUTS : 5 & 12v

- Primary / Secondary Insulation $\geq 4000V$
- Primary / Auxiliary Insulation $\geq 1500V$
- Creepage distance Primary / Secondary $\geq 6mm$
- Ambient temperature $< 50^{\circ}C$
- Construction conforms to IEC950, IEC335, IEC61558 for reinforced insulation
- Exclusively uses UL94-V0 listed materials

Bottom View (Pin side)

74010

PIN 3 Removed
PCB Drilling Diameter = 1.1mm

MYRRA P / N	Output Power maximum	Windings					
			Pins	Turns	Voltage	Current maximum	Inductance (+/-10%)
74010	12 w	Pri	4 - 6	120	60 - 125 (VOR)	0.55 Apeak	1660µH
		Aux	2 - 1	14	7 - 14 Vdc	0.1 Adc	
		S1	9 - 10	7	3.3 - 7 Vdc	2 Adc	
		S2	7 - 8	17	8 - 17 Vdc	1 Adc	

Examples of application with Integrated Circuits :

MYRRA P / N	Control IC Manufacturer	Control IC P / N	Input voltage	Power	Frequency
74010	Power Integrations	TNY267	185 - 265Vrms	12w	132kHz
	Power Integrations	TOP242P	85 - 265Vrms	10w	132kHz
	Power Integrations	TOP242P	185 - 265Vrms	12w	132kHz
	Power Integrations	TOP242P	85 - 265Vrms	10w	132kHz
	Power Integrations	TOP242P	185 - 265Vrms	12w	132kHz
	ST Microelectronics	VIPer20	85 - 265Vrms	8w	70kHz
	ST Microelectronics	VIPer20	185 - 265Vrms	10w	70kHz
	Motorola	MC33369	85 - 265Vrms	8w	100kHz
	Motorola	MC33369	185 - 265Vrms	10w	100kHz
	Infineon	TDA16831	92 - 265Vrms	7,5w	100kHz
	Infineon	TDA16831	185 - 265Vrms	10w	100kHz
	Fairchild	KA5L0165R	85 - 265Vrms	7w	50kHz
	Fairchild	KA5H0165RN	185 - 265Vrms	10w	100kHz



SIZE E16 • 2 OUTPUTS : 2 x 24v

- Primary / Secondary Insulation $\geq 4000V$
- Primary / Auxiliary Insulation $\geq 1500V$
- Creepage distance Primary / Secondary $\geq 6mm$
- Ambient temperature $< 50^{\circ}C$
- Construction conforms to IEC950, IEC335, IEC61558 for reinforced insulation
- Exclusively uses UL94-V0 listed materials

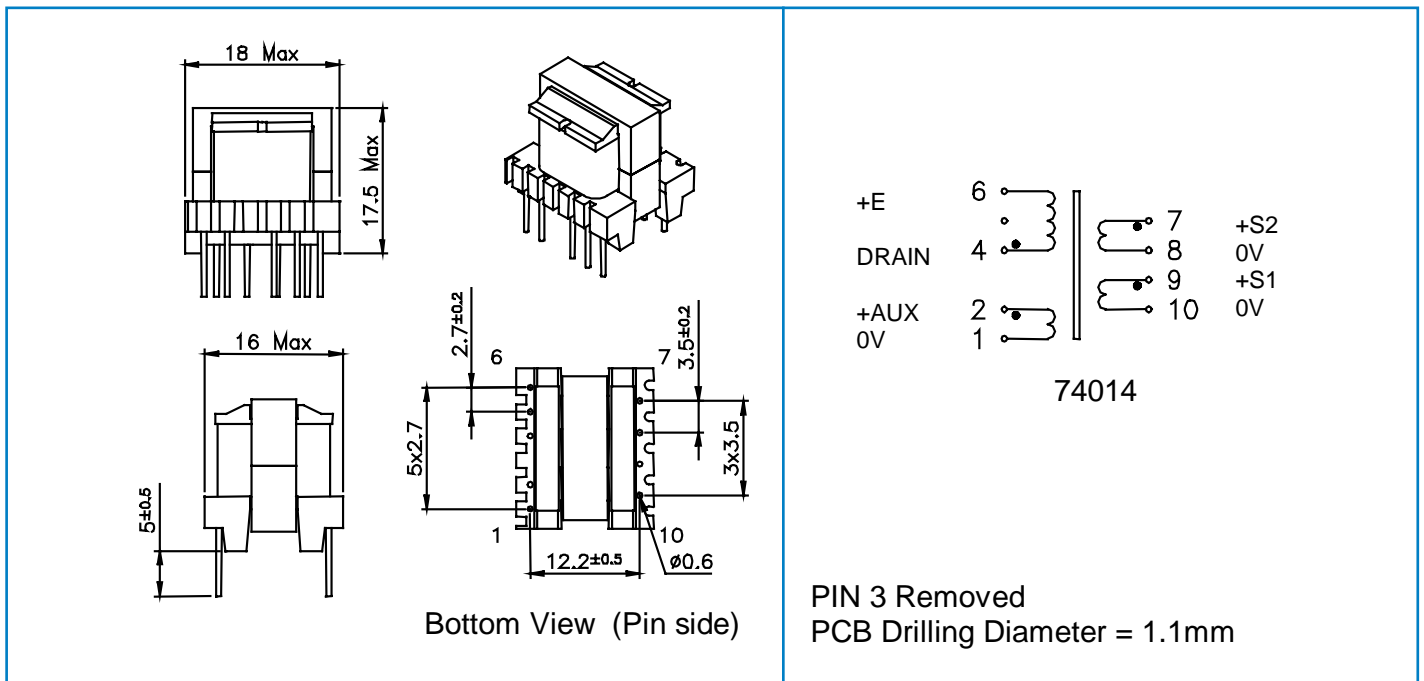

MYRRA P / N	Output Power maximum	Windings					
			Pins	Turns	Voltage	Current maximum	Inductance (+/-10%)
74014	12 w	Pri	4 - 6	120	70 - 140 (VOR)	0.5 Apeak	1800µH
		Aux	2 - 1	17	9 - 18 Vdc	0.2 Adc	
		S1	9 - 10	27	15 - 30 Vdc	0.4 Adc	
		S2	7 - 8	27	15 - 30 Vdc	0.4 Adc	

Typical outputs :

- +24V 0.5A with S1 – S2 in parallel
- +48V 0.25A with S1 – S2 in series (8-9 connected)
- +15V / -15V 0.4A with pins 8-9 connected to 0V

Examples of application with Integrated Circuits :

MYRRA P / N	Control IC Manufacturer	Control IC P / N	Input voltage	Power	Frequency
74014	Power Integrations	TNY266	185 - 265Vrms	12w	
	Power Integrations	TNY266	85 - 265Vrms	8w	
	Power Integrations	TOP242P	185 - 265Vrms	12w	132kHz
	Power Integrations	TOP242P	85 - 265Vrms	8w	132kHz

FF

SIZE E16 • 3 OUTPUTS : 5 / 15 / 24v

- Primary / Secondary Insulation $\geq 4000V$
- Primary / Auxiliary Insulation $\geq 1500V$
- Creepage distance Primary / Secondary $\geq 6mm$
- Ambient temperature $< 50^{\circ}C$
- Construction conforms to IEC950, IEC335, IEC61558 for reinforced insulation
- Exclusively uses UL94-V0 listed materials

18 Max
17.5 Max
16 Max
5±0.5
2.7±0.2
6
7
3.5±0.2
10
3x3.5
12.2±0.5
Ø0.6

Bottom View (Pin side)

+E 6
DRAIN 4
+AUX 2
0V 1

7 +S3
8 +S2
9 +S1
10 0V

74015

PIN 3 Removed
PCB Drilling Diameter = 1.1mm

MYRRA P / N	Output Power maximum	Windings					
			Pins	Turns	Voltage	Current maximum	Inductance (+/-10%)
74015	12 w	Pri	4 - 6	120	110 (VOR)	0.5 Apeak	1800µH
		Aux	2 - 1	14	12 Vdc	0.2 Adc	
		S1	9 - 10	6	5 Vdc	1.5 Adc	
		S2	8 - 10	17	15 Vdc	0.6 Adc	
		S3	7 - 10	27	24 Vdc	0.4 Adc	

Examples of application with Integrated Circuits :

MYRRA P / N	Control IC Manufacturer	Control IC P / N	Input voltage	Power	Frequency
74015	Power Integrations	TNY266	185 - 265Vrms	10w	
	Power Integrations	TNY266	85 - 265Vrms	8w	
	Power Integrations	TOP242P	185 - 265Vrms	12w	132kHz
	Power Integrations	TOP242P	85 - 265Vrms	9w	132kHz

FG

SIZE EL19 • 2 OUTPUTS : 5 & 12v

- Primary / Secondary Insulation $\geq 4000V$
- Primary / Auxiliary Insulation $\geq 1500V$
- Creepage distance Primary / Secondary $\geq 6mm$
- Ambient temperature $< 50^{\circ}C$
- Construction conforms to IEC950, IEC335, IEC61558 for reinforced insulation
- Exclusively uses UL94-V0 listed materials

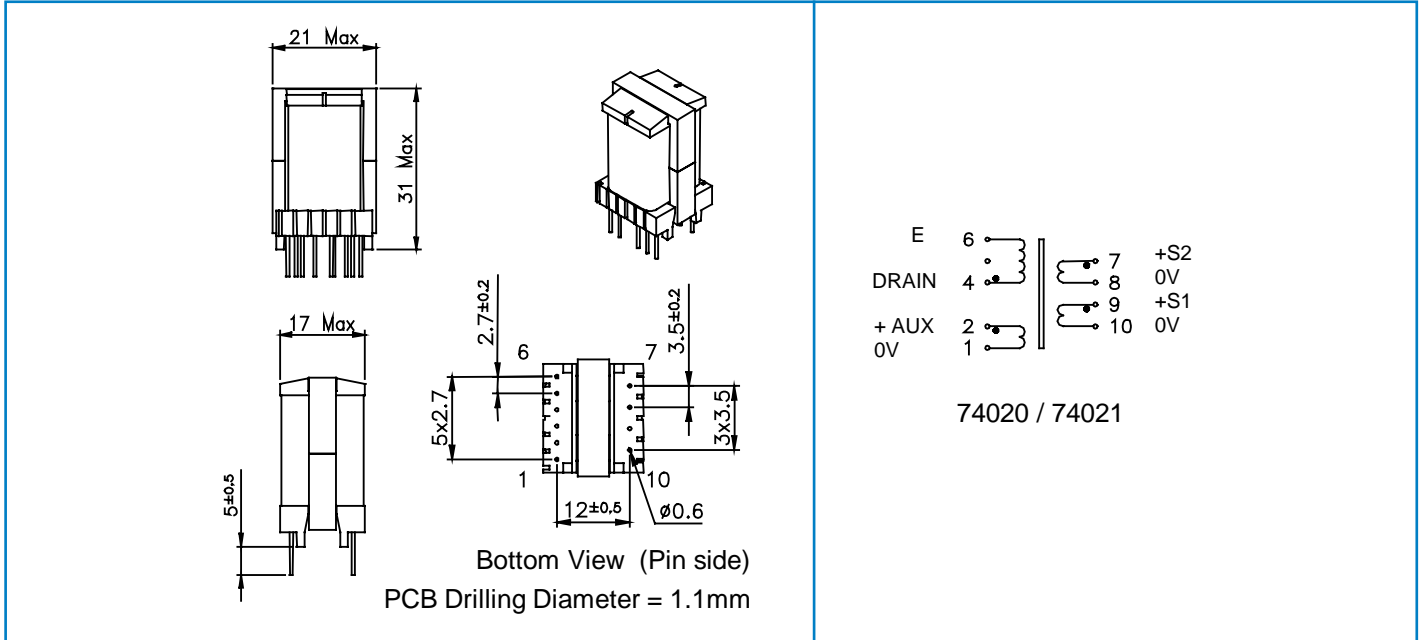

MYRRA P / N	Output Power maximum	Windings					
			Pins	Turns	Voltage	Current maximum	Inductance (+/-10%)
74020	18 w	Pri	4 - 6	108	65 – 130 (VOR)	0.8 Apeak	1250µH
		Aux	2 - 1	12	7 – 14 Vdc	0.1 Adc	
		S1	9 - 10	6	3.3 – 7 Vdc	3 Adc	
		S2	7 - 8	14	8 – 16.5 Vdc	1.4 Adc	
74021	18 w	Pri	4 - 6	108	65 – 130 (VOR)	1.1 Apeak	900µH
		Aux	2 - 1	12	7 – 14 Vdc	0.1 Adc	
		S1	9 - 10	6	3.3 – 7 Vdc	3 Adc	
		S2	7 - 8	14	8 – 16.5 Vdc	1.4 Adc	

Examples of application with Integrated Circuits :

MYRRA P / N	Control IC Manufacturer	Control IC P / N	Input voltage	Power	Frequency
74020	Power Integrations	TNY268	85 - 265Vrms	15w	132kHz
	Power Integrations	TOP243P	185 - 265Vrms	18w	132kHz
	Power Integrations	TOP243P	85 - 265Vrms	12w	132kHz
	ST Microelectronics	VIPer20	85 - 265Vrms	10w	100kHz
	ST Microelectronics	VIPer20	185 - 265Vrms	12w	100kHz
	ST Microelectronics	VIPer50	185 - 265Vrms	16w	100kHz
	Motorola	MC33370	185 - 265Vrms	16w	100kHz
	Infineon	TDA16832	185 - 265Vrms	16w	100kHz
74021	ST Microelectronics	VIPer50	85 - 265Vrms	13w	70kHz
	Motorola	MC33370	85 - 265Vrms	13w	100kHz
	Infineon	TDA16831	92 - 265Vrms	10w	100kHz

SIZE EL19 • 5 OUTPUTS : 3.3 / 5 / 12 / 18 / 30v

- Primary / Secondary Insulation $\geq 4000V$
- Primary / Auxiliary Insulation $\geq 1500V$
- Creepage distance Primary / Secondary $\geq 6mm$
- Ambient temperature $< 60^{\circ}C$
- Construction conforms to IEC950, IEC335, IEC61558 for reinforced insulation
- Exclusively uses UL94-V0 listed materials

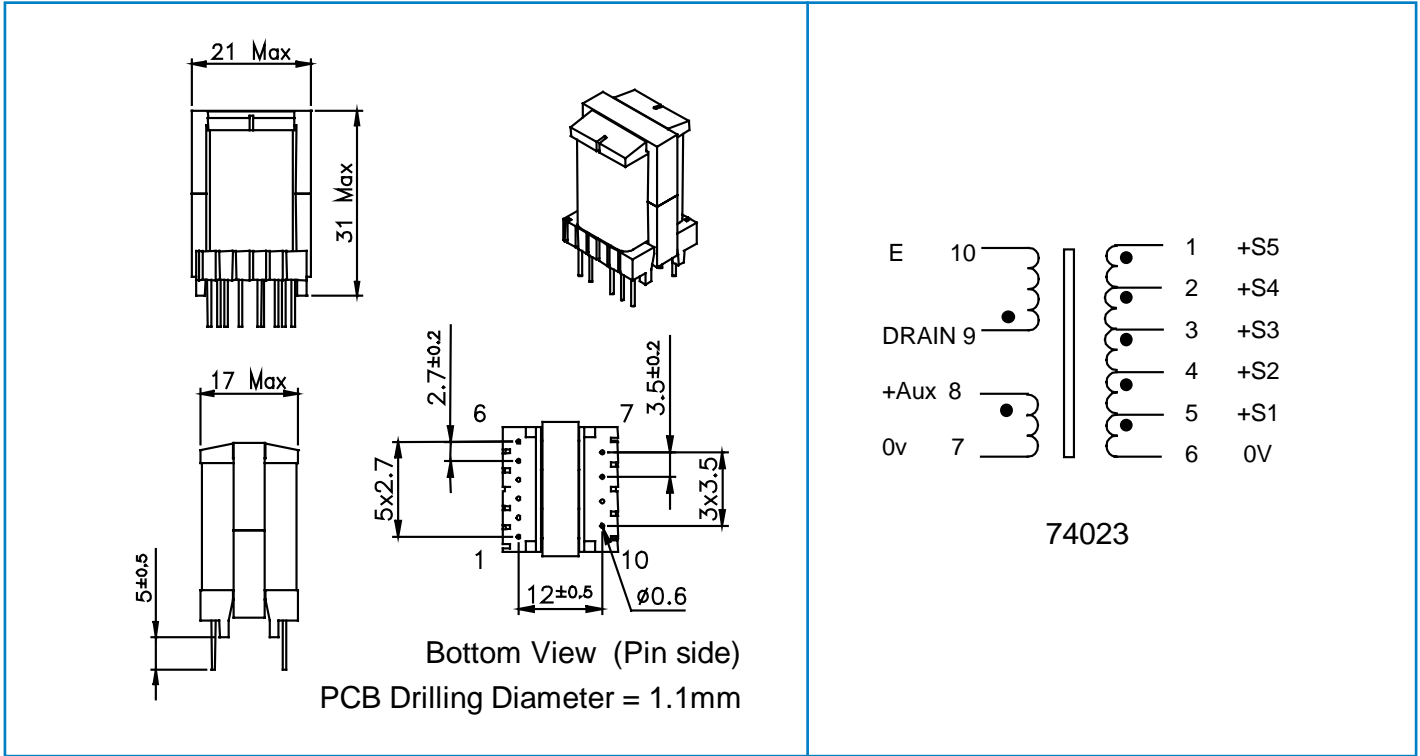

MYRRA P / N	Output Power maximum	Windings					
			Pins	Turns	Voltage	Current maximum	Inductance (+/-10%)
74023	16 w	Pri	9 - 10	120	110 (VOR)	0.85 Apeak	1250µH
		Aux	8 - 7	17	15 Vdc	0.2 Adc	
		S1	5 - 6	4	3.3 Vdc	2 Adc	
		S2	4 - 6	6	5 Vdc	Sum S1+S2	
		S3	3 - 6	14	12 Vdc	0.8 Adc	
		S4	2 - 6	20	18 Vdc	0.8 Adc	
		S5	1 - 6	33	30 Vdc	0.2 Adc	

Examples of application with Integrated Circuits :

MYRRA P / N	Control IC Manufacturer	Control IC P / N	Input voltage	Power	Frequency
74023	Power Integrations	TOP243P	185 - 265Vrms	16w	132kHz
	Power Integrations	TOP243P	85 - 265Vrms	12w	132kHz

SIZE EF20 • 2 or 3 OUTPUTS : 5/5v or 12/12v or 3.3+5/12v

- Primary / Secondary Insulation $\geq 4000V$
- Primary / Auxiliary Insulation $\geq 1500V$
- Creepage distance Primary / Secondary $\geq 8mm$
- Ambient temperature $< 50^{\circ}C$
- Construction conforms to IEC950, IEC335, IEC61558 for reinforced insulation
- Exclusively uses UL94-V0 listed materials

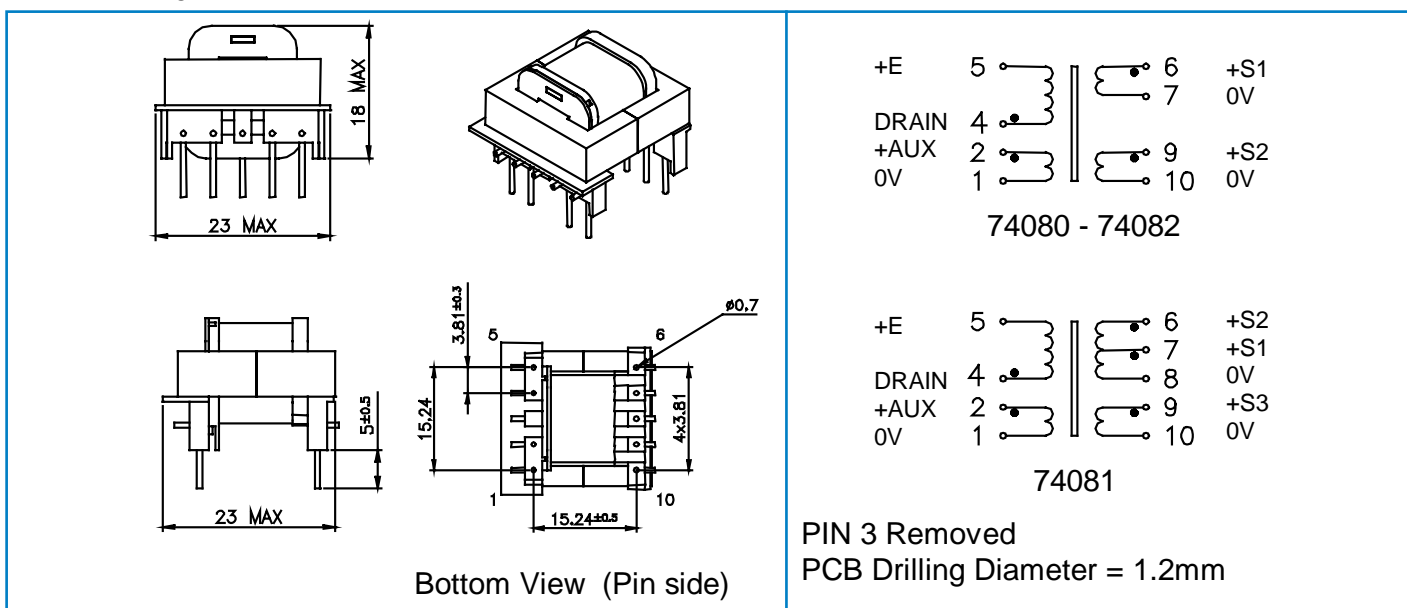

MYRRA P / N	Output Power maximum	Windings					
			Pins	Turns	Voltage	Current maximum	Inductance (+/-10%)
74080	24 w	Pri	4 - 5	86	80 - 135 (VOR)	1.0 Apeak	1000µH
		Aux	2 - 1	12	11 - 18 Vdc	0.3 Adc	
		S1	6 - 7	10	9 - 15 Vdc	1.5 Adc	
		S2	9 - 10	10	9 - 15 Vdc	1.5 Adc	
74081	20 w	Pri	4 - 5	80	75 (VOR)	0.9 Apeak	1100µH
		Aux	2 - 1	17	15 Vdc	0.3 Adc	
		S1	7 - 8	4	3.3 Vdc	3 Adc	
		S2	6 - 8	6	5 Vdc	Sum S1+S2	
		S3	9 - 10	14	12 Vdc	1.3 Adc	
74082	20 w	Pri	4 - 5	86	60 - 135 (VOR)	0.85 Apeak	1300µH
		Aux	2 - 1	12	7 - 18 Vdc	0.3 Adc	
		S1	6 - 7	5	3 - 7.5 Vdc	2.0 Adc	
		S2	9 - 10	5	3 - 7.5 Vdc	2.0 Adc	

Note for 74080 and 74082 : S1 and S2 can be connected in series or in parallel

Examples of application with Integrated Circuits :

MYRRA P / N	Control IC Manufacturer	Control IC P / N	Input voltage	Power	Frequency
74080	Power Integrations	TOP243P	185 - 265Vrms	24w	132kHz
	Power Integrations	TOP243P	85 - 265Vrms	15w	132kHz
74081	Power Integrations	TOP243P	185 - 265Vrms	20w	132kHz
	Power Integrations	TOP243P	85 - 265Vrms	12w	132kHz
74082	Power Integrations	TOP243P	185 - 265Vrms	20w	132kHz
	Power Integrations	TOP243P	85 - 265Vrms	14w	132kHz
	Power Integrations	TNY268	185 - 265Vrms	17w	< 120kHz

FI

SIZE E25 • 3 or 1 OUTPUTS : 5+12/12v or 24v

FLYBACK TRANSFORMER

- Primary / Secondary Insulation $\geq 4000V$
- Primary / Auxiliary Insulation $\geq 1500V$
- Creepage distance Primary / Secondary $\geq 6mm$
- Ambient temperature $< 50^{\circ}C$
- Construction conforms to IEC950, IEC335, IEC61558 for reinforced insulation
- Exclusively uses UL94-V0 listed materials

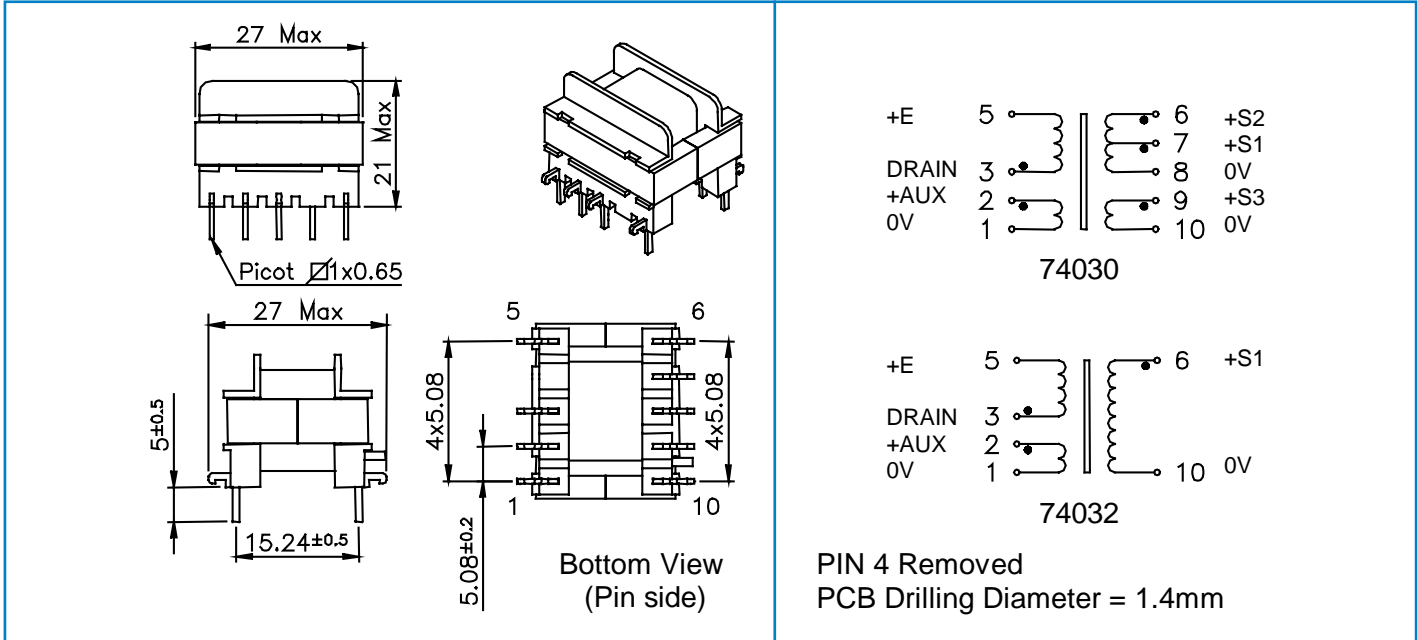

MYRRA P / N	Output Power maximum	Windings					
			Pins	Turns	Voltage	Current maximum	Inductance (+/-10%)
74030	30 w	Pri	3 - 5	70	65 - 130 (VOR)	1.5 Apeak	750μH
		Aux	2 - 1	8	7 - 14.5 Vdc	1 Adc	
		S1	7 - 8	4	3.3 - 7	3 Adc	
		S2	6 - 8	9	8 - 16 Vdc	1.5 Adc	
		S3	9 - 10	9	8 - 16 Vdc	1.5 Adc	
74032	35 w	Pri	3 - 5	72	62 - 125 (VOR)	1.1 Apeak	1100μH
		Aux	2 - 1	10	8 - 16 Vdc	1 Adc	
		S1	6 - 10	18	15 - 30 Vdc	1.4 Adc	

Note for 74030 : S2 and S3 can be connected in series or in parallel

Examples of application with Integrated Circuits :

MYRRA P / N	Control IC Manufacturer	Control IC P / N	Input voltage	Power	Frequency
74030	Power Integrations	TOP244P	185 - 265Vrms	30w	132kHz
	Power Integrations	TOP244Y	85 - 265Vrms	25w	66 or 132kHz
	ST Microelectronics	VIPer50	85 - 265Vrms	22w	70kHz
	ST Microelectronics	VIPer50	185 - 265Vrms	30w	70kHz
	Motorola	MC33371	85 - 265Vrms	22w	100kHz
	Motorola	MC33371	185 - 265Vrms	30w	100kHz
	Infineon	TDA16832	185 - 265Vrms	30w	100kHz
	Fairchild	KA1H0265R	85 - 265Vrms	22w	100kHz
74032	Power Integrations	TOP244P	185 - 265Vrms	25w	132kHz

**FLYBACK
TRANSFORMER**



SIZE ETD29 • 4 OUTPUTS : 5+12 / 5+12v

- Primary / Secondary Insulation $\geq 4000V$
- Primary / Auxiliary Insulation $\geq 1500V$
- Creepage distance Primary / Secondary $\geq 8mm$
- Ambient temperature $< 50^{\circ}C$
- Construction conforms to IEC950, IEC335, IEC61558 for reinforced insulation
- Exclusively uses UL94-V0 listed materials

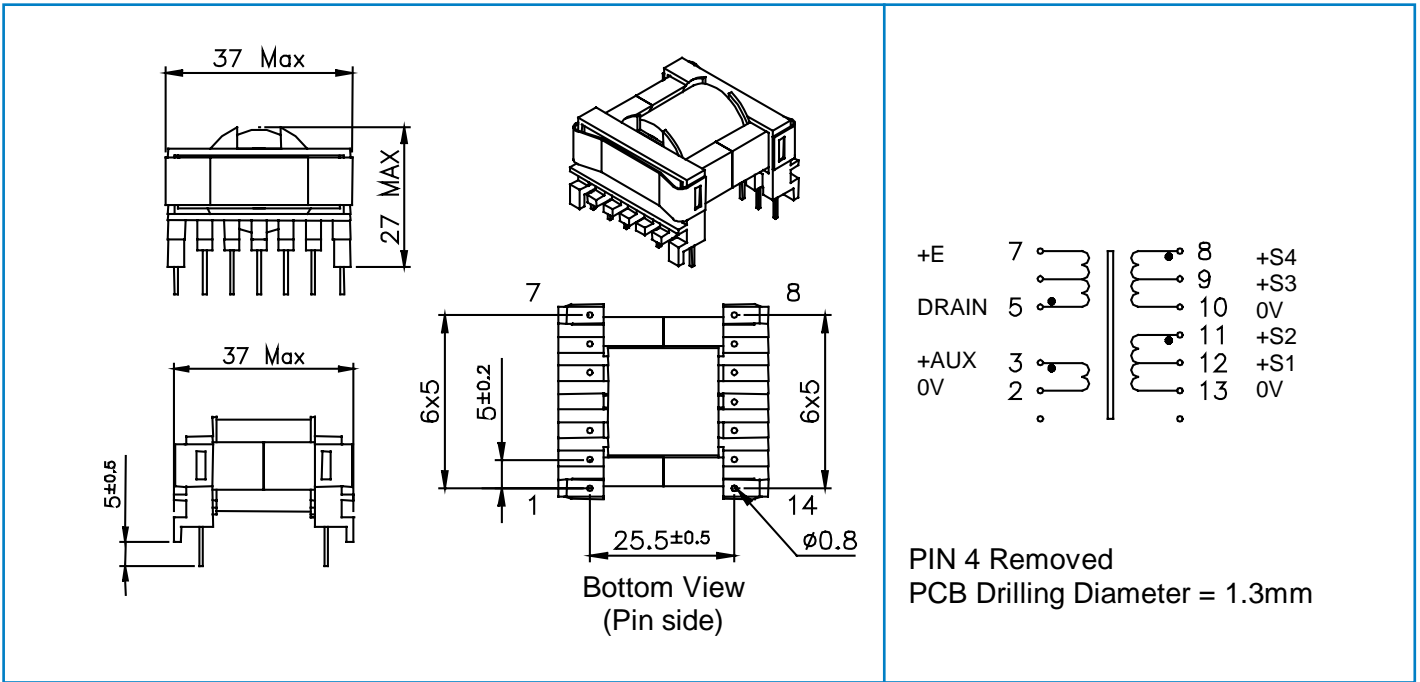

MYRRA P / N	Output Power maximum	Windings					
			Pins	Turns	Voltage	Current maximum	Inductance (+/-10%)
74040	60 w	Pri	5 - 7	50	60 - 125 (VOR)	3.0 Apeak	500µH
		Aux	3 - 2	6	7 - 14.5 Vdc	0.5 Adc	
		S1	12 - 13	3	3.3 - 7	4 Adc	
		S2	11 - 13	7	8 - 16.5 Vdc	2.5 Adc	
		S3	9 - 10	3	3.3 - 7	4 Adc	
		S4	8 - 10	7	8 - 16.5 Vdc	2.5 Adc	

Note : S1 / S3 or S2 / S4 can be connected in series or in parallel

Examples of application with Integrated Circuits :

MYRRA P / N	Control IC Manufacturer	Control IC P / N	Input voltage	Power	Frequency
74040	Power Integrations	TOP245Y	185 - 265Vrms	60w	66 or 132kHz
	Power Integrations	TOP245Y	85 - 265Vrms	45w	66 or 132kHz
	ST Microelectronics	VIPer50	85 - 265Vrms	35w	100kHz
	ST Microelectronics	VIPer50	185 - 265Vrms	45w	100kHz
	Motorola	MC33372	85 - 265Vrms	35w	100kHz
	Motorola	MC33372	185 - 265Vrms	45w	100kHz
	Infineon	TDA16834	92 - 265Vrms	35w	100kHz
	Infineon	TDA16834	185 - 265Vrms	45w	100kHz

SIZE ERL28 • 5 OUTPUTS : 3.3 / 5 / 12 / 18 / 30v

- Primary / Secondary Insulation $\geq 4000V$
- Primary / Auxiliary Insulation $\geq 1500V$
- Creepage distance Primary / Secondary $\geq 6mm$
- Ambient temperature $< 50^{\circ}C$
- Construction conforms to IEC950, IEC335, IEC61558 for reinforced insulation
- Exclusively uses UL94-V0 listed materials

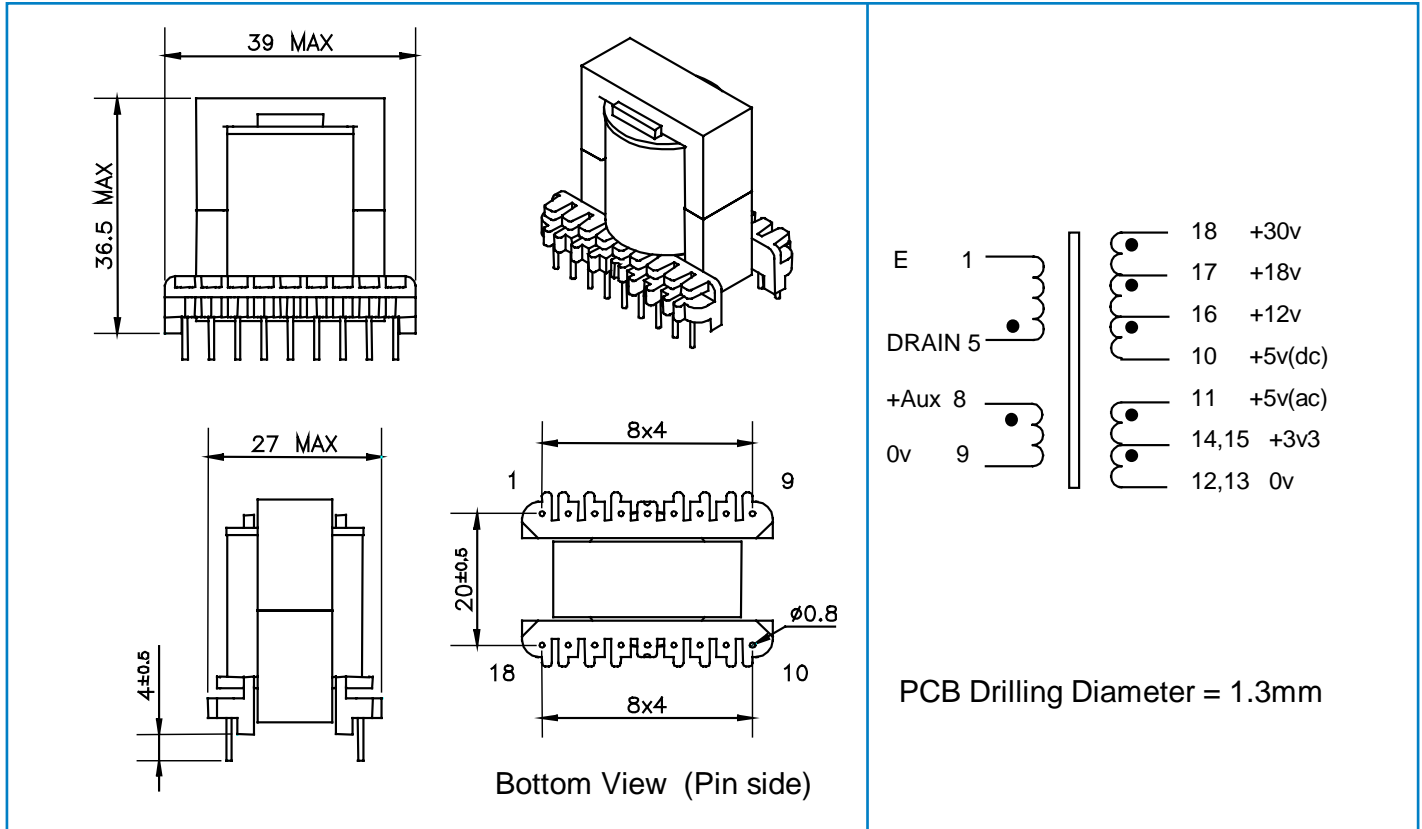

MYRRA P / N	Output Power maximum	Windings					
			Pins	Turns	Voltage	Current maximum	Inductance (+/-10%)
74043	60w	Pri	5 - 1	45	90 (VOR)	3 Apeak	500µH
		Aux	8 - 9	7	15 Vdc	0.5 Adc	
		S1	14+15 / 12+13	2	3.3 Vdc	7 Adc	
		S2	11 / 12+13	3	5 Vdc	Sum S1+S2	
		S3	16 - 10	4	12 Vdc	2 Adc	
		S4	17 - 10	7	18 Vdc	2 Adc	
		S5	18 - 10	13	30 Vdc	0.5 Adc	

Examples of application with Integrated Circuits :

MYRRA P / N	Control IC Manufacturer	Control IC P / N	Input voltage	Power	Frequency
74043	Power Integrations	TOP246Y	185 - 265Vrms	60w	66 or 132kHz
	Power Integrations	TOP246Y	85 - 265Vrms	45w	66 or 132kHz

SIZE ETD34 • 4 OUTPUTS : 5+12 / 5+12v

- Primary / Secondary Insulation $\geq 4000V$
- Primary / Auxiliary Insulation $\geq 1500V$
- Creepage distance Primary / Secondary $\geq 8mm$
- Ambient temperature $< 50^{\circ}C$
- Construction conforms to IEC950, IEC335, IEC61558 for reinforced insulation
- Exclusively uses UL94-V0 listed materials

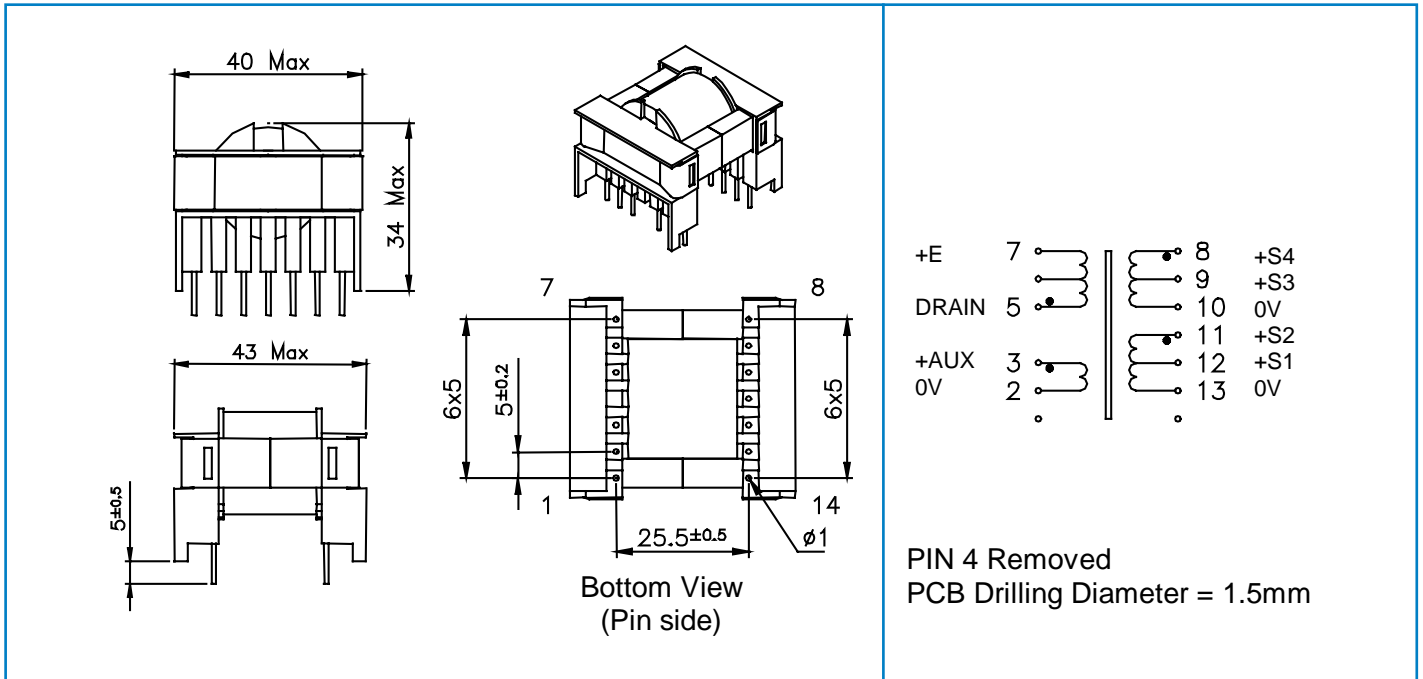

MYRRA P / N	Output Power maximum	Windings					
			Pins	Turns	Voltage	Current maximum	Inductance (+/-10%)
74050	90 w	Pri	5 - 7	36	65 - 125 (VOR)	2.8 Apeak	500 μ H
		Aux	3 - 2	4	7 - 14 Vdc	0.5 Adc	
		S1	12 - 13	2	3.3 - 6.5	5 Adc	
		S2	11 - 13	5	8.5 - 17 Vdc	3 Adc	
		S3	9 - 10	2	3.3 - 6.5	5 Adc	
		S4	8 - 10	5	8.5 - 17 Vdc	3 Adc	

Note : S1 / S3 or S2 / S4 can be connected in series or in parallel

Examples of application with Integrated Circuits :

MYRRA P / N	Control IC Manufacturer	Control IC P / N	Input voltage	Power	Frequency
74050	Power Integrations	TOP246Y	185 - 265Vrms	90w	132kHz
	Power Integrations	TOP246Y	85 - 265Vrms	60w	66 or 132kHz
	ST Microelectronics	VIPer100A	185 - 265Vrms	80w	70kHz
	ST Microelectronics	VIPer100A	85 - 265Vrms	60w	70kHz
	Motorola	MC33373	185 - 265Vrms	80w	100kHz
	Motorola	MC33373	85 - 265Vrms	60w	100kHz
	Infineon	TDA16834	185 - 265Vrms	80w	100kHz
	Infineon	TDA16836	85 - 265Vrms	60w	100kHz

SIZE ETD39 • 4 OUTPUTS : 5+12 / 5+12v

- Primary / Secondary Insulation $\geq 4000V$
- Primary / Auxiliary Insulation $\geq 1500V$
- Creepage distance Primary / Secondary $\geq 8mm$
- Ambient temperature $< 50^{\circ}C$
- Construction conforms to IEC950, IEC335, IEC61558 for reinforced insulation
- Exclusively uses UL94-V0 listed materials

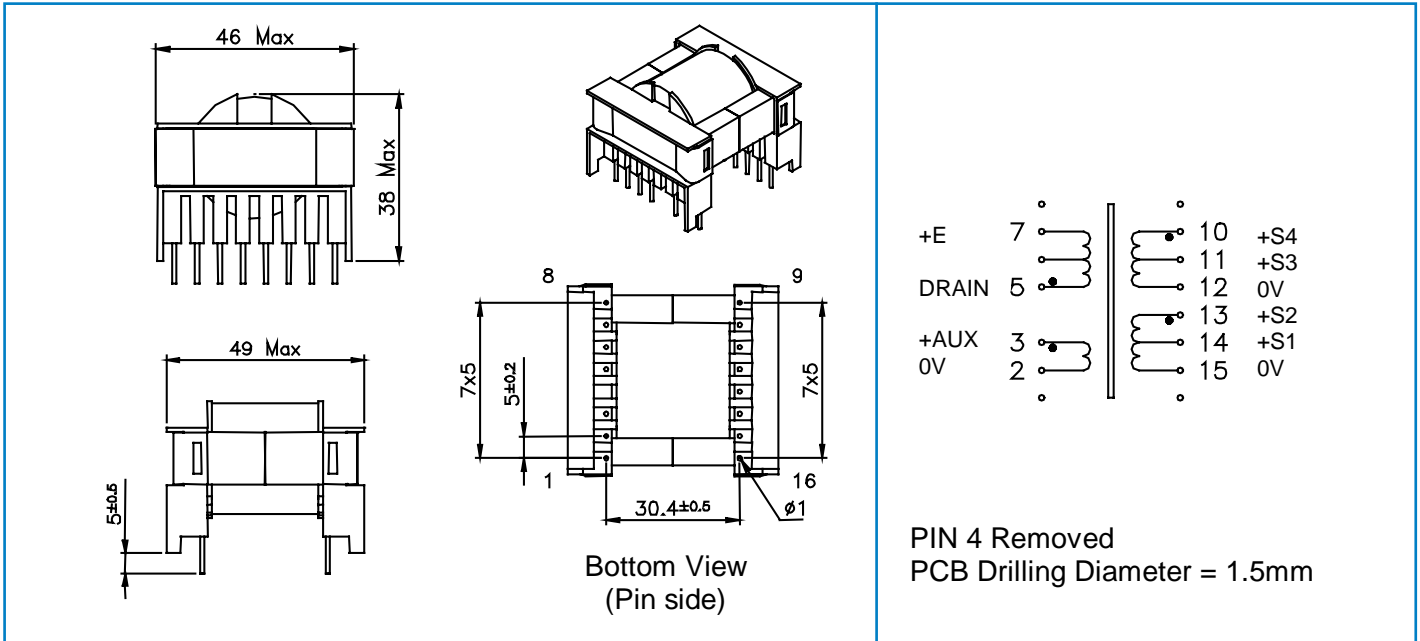

MYRRA P / N	Output Power maximum	Windings					
			Pins	Turns	Voltage	Current maximum	Inductance (+/-10%)
74060	140 w	Pri	5 – 7	36	65 – 125 (VOR)	4 Apeak	440µH
		Aux	3 – 2	4	7 – 14 Vdc	0.5 Adc	
		S1	14 – 15	2	3.3 – 6.5	5 Adc	
		S2	13 – 15	5	8.5 – 17 Vdc	5 Adc	
		S3	11 – 12	2	3.3 – 6.5	5 Adc	
		S4	10 – 12	5	8.5 – 17 Vdc	5 Adc	

Note : S1 / S3 or S2 / S4 can be connected in series or in parallel

Examples of application with Integrated Circuits :

MYRRA P / N	Control IC Manufacturer	Control IC P / N	Input voltage	Power	Frequency
74060	Power Integrations	TOP247Y	185 - 265Vrms	140w	132kHz
	Power Integrations	TOP247Y	85 - 265Vrms	90w	66 or 132kHz
	ST Microelectronics	VIPer100A	85 - 265Vrms	70w	70kHz
	ST Microelectronics	VIPer100A	185 - 265Vrms	120w	100kHz
	Motorola	MC33374	85 - 265Vrms	70w	100kHz
	Motorola	MC33374	185 - 265Vrms	120w	100kHz
	Infineon	TDA16836	85 - 265Vrms	70w	100kHz
	Infineon	TDA16836	185 - 265Vrms	120w	100kHz
	Fairchild	KA1H0565R	85 - 265Vrms	70w	100kHz
Fairchild	KA1H0565R	185 - 265Vrms	120w	100kHz	



FLYBACK TRANSFORMER

SIZE ETD44 • 4 OUTPUTS : 5+12 / 5+12V

- Primary / Secondary Insulation $\geq 4000V$
- Primary / Auxiliary Insulation $\geq 1500V$
- Creepage distance Primary / Secondary $\geq 8mm$
- Ambient temperature $< 50^{\circ}C$
- Construction conforms to IEC950, IEC335, IEC61558 for reinforced insulation
- Exclusively uses UL94-V0 listed materials

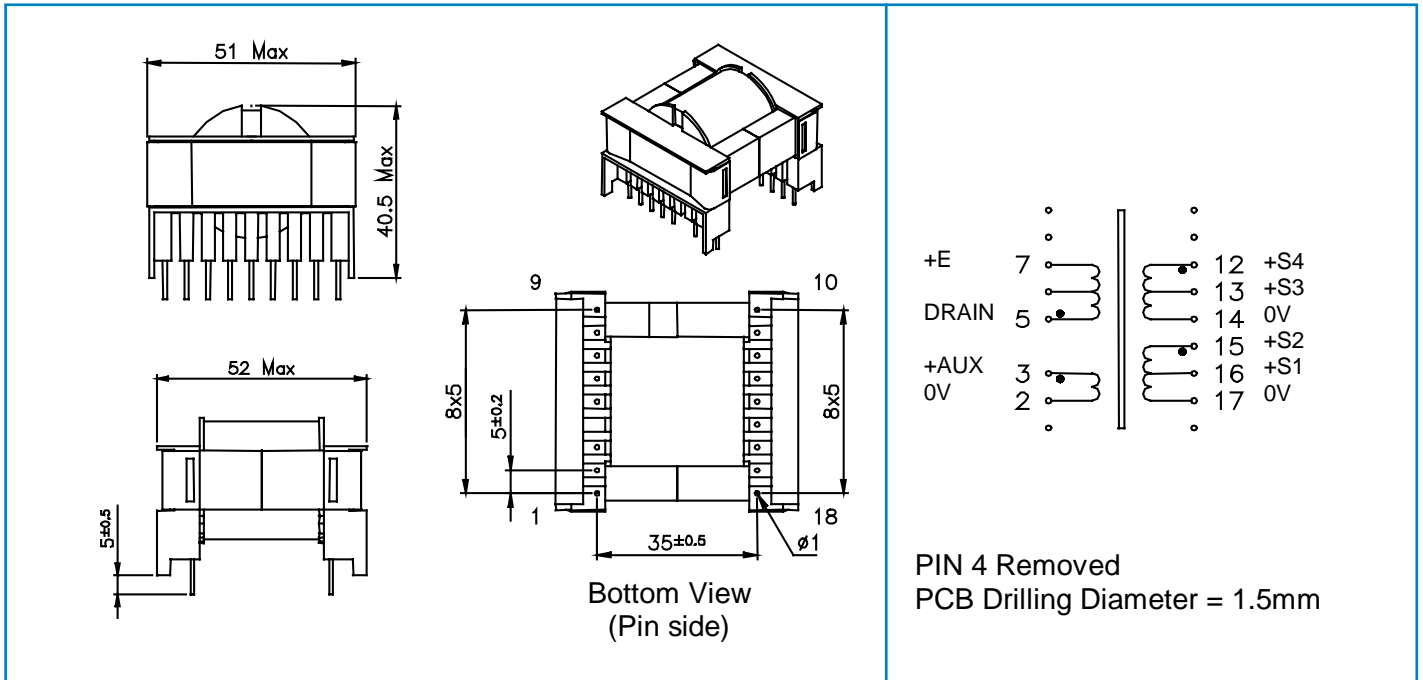

MYRRA P / N	Output Power maximum	Windings					
			Pins	Turns	Voltage	Current maximum	Inductance (+/-10%)
74070	180 w	Pri	5 – 7	38	65 – 125 (VOR)	8 Apeak	300µH
		Aux	3 – 2	4	7 – 14 Vdc	0.5 Adc	
		S1	16 – 17	2	3.3 – 6.5	6 Adc	
		S2	15 – 17	5	8.5 – 17 Vdc	5 Adc	
		S3	13 – 14	2	3.3 – 6.5	6 Adc	
		S4	12 – 14	5	8.5 – 17 Vdc	5 Adc	

Note : S1 / S3 or S2 / S4 can be connected in series or in parallel

Examples of application with Integrated Circuits :

MYRRA P / N	Control IC Manufacturer	Control IC P / N	Input voltage	Power	Frequency
74070	Power Integrations	TOP248Y	185 - 265Vrms	180w	66 or 132kHz
		TOP249Y			
	Power Integrations	TOP249Y	85 - 265Vrms	120w	66kHz
	Infineon	TDA16837	185 - 265Vrms	160w	100kHz
	Fairchild	KA2S0965	185 - 265Vrms	160w	100kHz
Philips	TEA1566	185 - 265Vrms	120w	50kHz	



COMMON MODE CHOKES RANGE FOR EMI SUPPRESSION

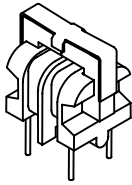

U9.8

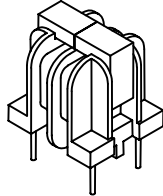

U10.5

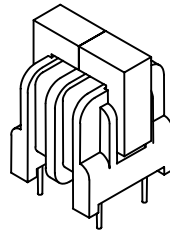

U16

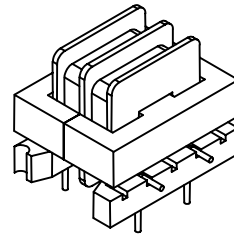

E25

- Mainly used to reduce noise conducted through power or signal lines.
- The common mode inductance filters symmetrical noise, associated with Y-type safety capacitors connected to ground.
- The differential mode inductance filters asymmetrical noise, associated with X-type capacitor connected between Line and Neutral.

MYRRA Part N°	SIZE	Inductance range	Current range
74330 - 74335	U9.8	1.5 to 47mH	0.18 to 1.1A
74300 - 74306	U10.5	1.5 to 68mH	0.30 to 1.9A
74310 - 74315	U16	1.5 to 33mH	0.75 to 3.3A
74320 - 74325	E25	1.5 to 33mH	0.90 to 4.0A

COMMON MODE CHOKES FOR EMI SUPPRESSION

- Ambient Temperature $\leq 50^{\circ}\text{C}$
- Dielectric Strength $\geq 1.5\text{ kV}$ between windings
- Electrical characteristics at 25°C

SIZE : U9.8

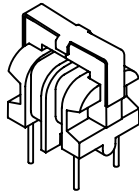

ELECTRICAL CHARACTERISTICS :

MYRRA Part N°	Inductance Common Mode min - max (mH)	Rated Current Arms	Resistance per winding ohm max	Inductance Differential Mode μH min	Resonant Frequency kHz min
74330	33 - 56	0.18	7	710	210
74331	18 - 31	0.26	3.5	360	280
74332	10 - 17	0.35	2.0	210	400
74333	4.7 - 8	0.5	.95	100	610
74334	2.2 - 3.7	0.8	.4	45	910
74335	1 - 1.7	1.1	.21	20	1300

MECHANICAL CHARACTERISTICS / PINOUT :

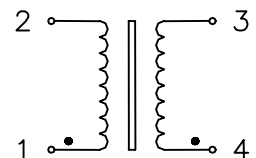
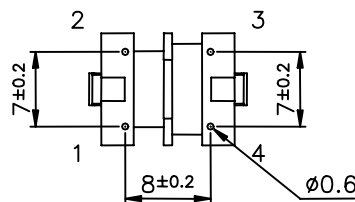
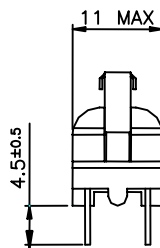
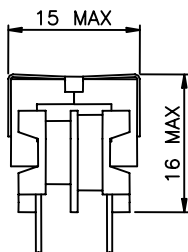

View from pin side
PCB Drilling diameter 1.0 mm

COMMON MODE CHOKES FOR EMI SUPPRESSION

- Ambient Temperature $\leq 50^{\circ}\text{C}$
- Dielectric Strength $\geq 1.5\text{ kV}$ between windings
- Electrical characteristics at 25°C

SIZE : U10.5

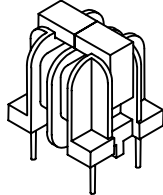

ELECTRICAL CHARACTERISTICS :

MYRRA Part N°	Inductance Common Mode min - max (mH)	Rated Current Arms	Resistance per winding ohm max	Inductance Differential Mode μH min	Resonant Frequency kHz min
74306	51 - 85	0.3	4	530	125
74300	33 - 56	0,35	3	400	170
74301	18 - 31	0,45	1,7	240	220
74302	10 - 17	0,6	1	140	320
74303	4.7 - 8	0,9	0,43	65	480
74304	2.2 - 3.7	1,3	0,23	32	740
74305	1 - 1.7	1,9	0,1	14	1000

MECHANICAL CHARACTERISTICS / PINOUT :

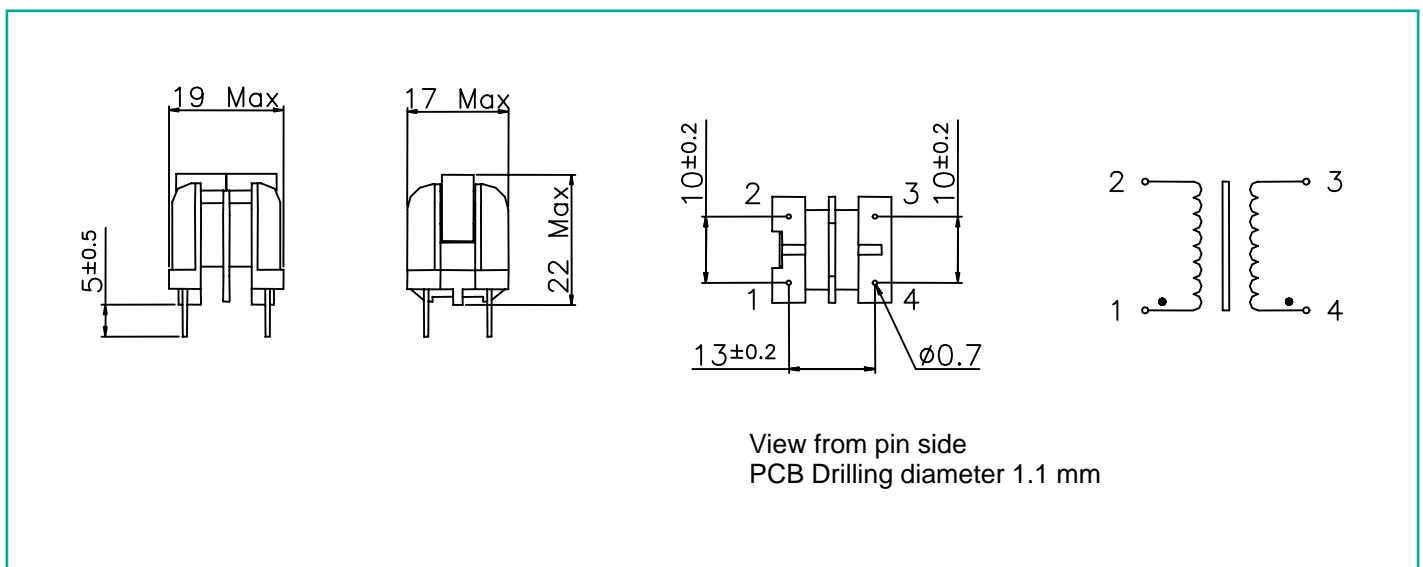



COMMON MODE CHOKES FOR EMI SUPPRESSION

- Ambient Temperature $\leq 50^{\circ}\text{C}$
- Dielectric Strength $\geq 1.5 \text{ kV}$ between windings
- Electrical characteristics at 25°C

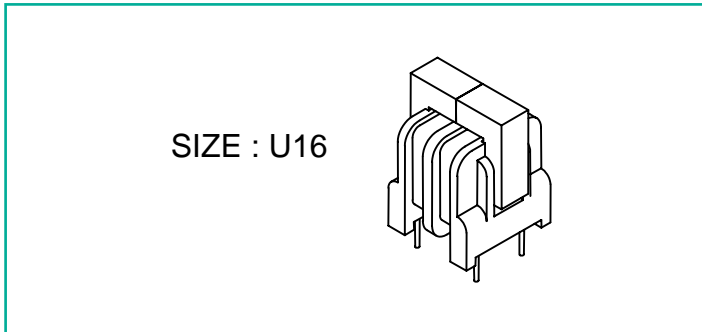

ELECTRICAL CHARACTERISTICS :

MYRRA Part N°	Inductance Common Mode min - max (mH)	Rated Current Arms	Resistance per winding ohm max	Inductance Differential Mode μH min	Resonant Frequency kHz min
74310	22 - 37	0,75	1	230	170
74311	15 - 25	0,9	0,75	150	210
74312	10 - 17	1,1	0,44	100	280
74313	4.7 - 8	1,5	0,24	50	440
74314	2.2 - 3.7	2,3	0,095	20	650
74315	1 - 1.7	3,3	0,046	10	1000

MECHANICAL CHARACTERISTICS / PINOUT :

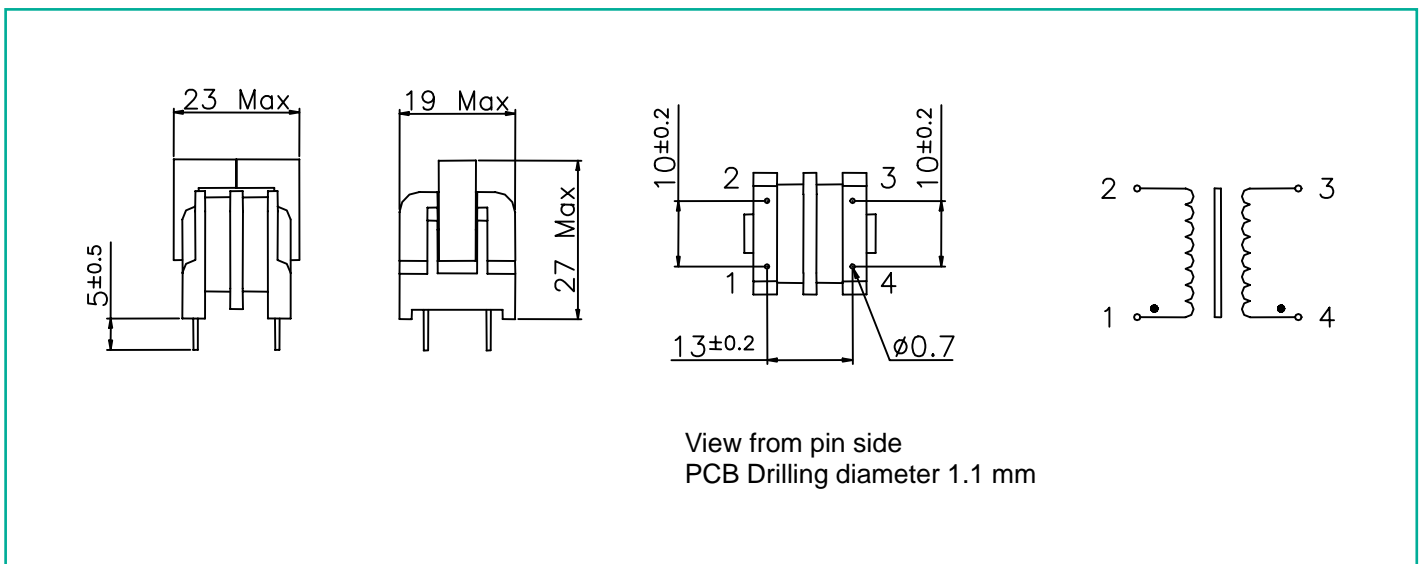

COMMON MODE CHOKES FOR EMI SUPPRESSION

- Ambient Temperature $\leq 50^{\circ}\text{C}$
- Dielectric Strength $\geq 1.5 \text{ kV}$ between windings
- Electrical characteristics at 25°C

SIZE : E25

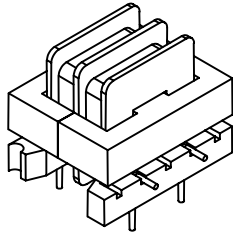

ELECTRICAL CHARACTERISTICS :

MYRRA Part N°	Inductance Common Mode min - max (mH)	Rated Current Arms	Resistance per winding ohm max	Inductance Differential Mode μH min	Resonant Frequency kHz min
74320	22 - 37	0,9	0,54	130	170
74321	15 - 25	1,1	0,35	90	210
74322	10 - 17	1,3	0,22	50	270
74323	4.7 - 8	1,8	0,105	25	400
74324	2.2 - 3.7	2,7	0,05	11	630
74325	1 - 1.7	4	0,03	7	950

MECHANICAL CHARACTERISTICS / PINOUT :

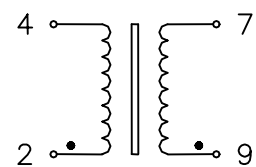
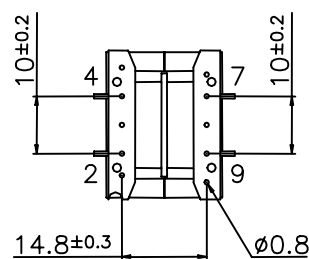
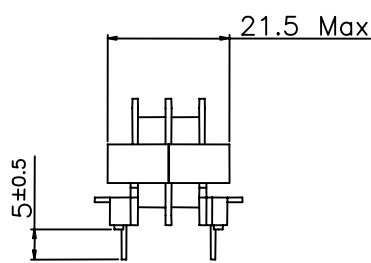
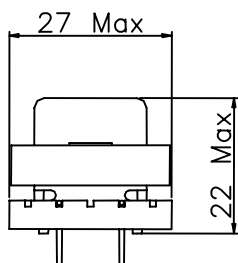

View from pin side
PCB Drilling diameter 1.2 mm

DIMMER CHOKES FOR EMI SUPPRESSION

- For noise suppression in light dimmers
- Saturable chokes : provides a high impedance for Triac switching interferences, and a low impedance for 50Hz component.
- Electrical characteristics at 25 °

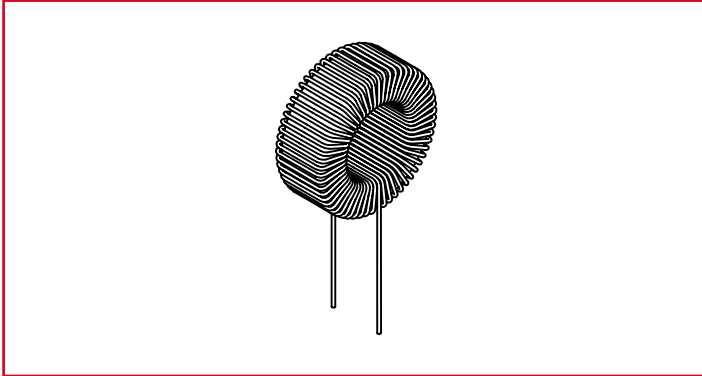

ELECTRICAL CHARACTERISTICS :

MYRRA Part N°	Power	Inductance +/- 15 %	Rated Current	Resistance	Associated Capacitor	Dimensions (mm)				Approx. Weight
						OD max	OD min	H max	W max	
74190	150 w	3.5 mH	0.7 Arms	1.5 Ω	22 nF	24	9	9.5	0.5	13 g
74191	300 w	2.8 mH	1.3 Arms	0.73 Ω	47 nF	29	10	11	0.7	24 g
74192	500 w	2.0 mH	2.2 Arms	0.35 Ω	82 nF	32.5	9	16	0.9	47 g
74196	500 w	1.8 mH	2.2 Arms	0.37 Ω	82 nF	38	14	12	0.9	39 g
74193	1000 w	1.3 mH	4.5 Arms	0.15 Ω	220 nF	44	14	16.5	1.2	80 g
74194	2200 w	450 μH	10 Arms	0.04 Ω	470 nF	50	15	22.5	1.8	140 g
74195	4500 w	250 μH	20 Arms	0.014 Ω	1 μF	58	15	27	2.5	250 g

MECHANICAL CHARACTERISTICS :

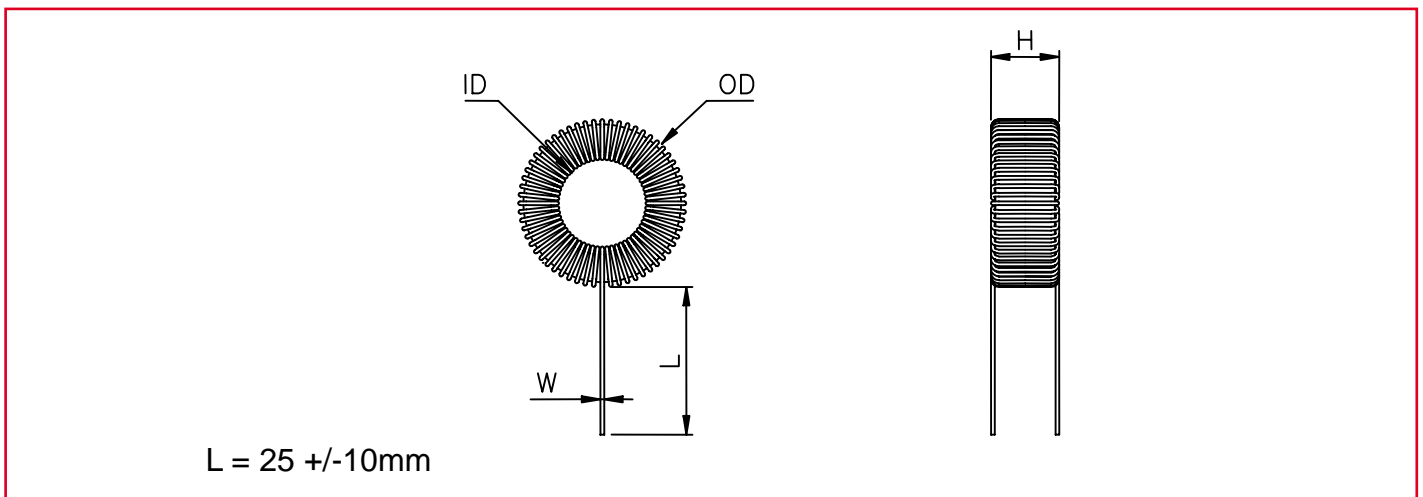

DRUM CORE CHOKES



- For use as filtering or DC/DC power conversion.
- Electrical characteristics given for 25 °C
- Ambient temperature up to 70°C without derating
- Models 74460 & 74461 are designed to make a non-isolated supply in association with Power Integrations TinySwitch integrated circuits.

ELECTRICAL CHARACTERISTICS :

MYRRA Part N°	Inductance +/- 10 %	Rated Current	Saturation Current	Resistance max
74450	10 μ H	5.0 Arms	6.5 Apeak	0.016 Ω
74451	22 μ H	3.5 Arms	4.2 Apeak	0.031 Ω
74452	47 μ H	2.4 Arms	2.9 Apeak	0.07 Ω
74453	100 μ H	1.5 Arms	2.0 Apeak	0.15 Ω
74454	220 μ H	1.1 Arms	1.35 Apeak	0.30 Ω
74460	470 μ H	0.7 Arms	0.95 Apeak	0.70 Ω
74461	820 μ H	0.55 Arms	0.7 Apeak	1.15 Ω

MECHANICAL CHARACTERISTICS :

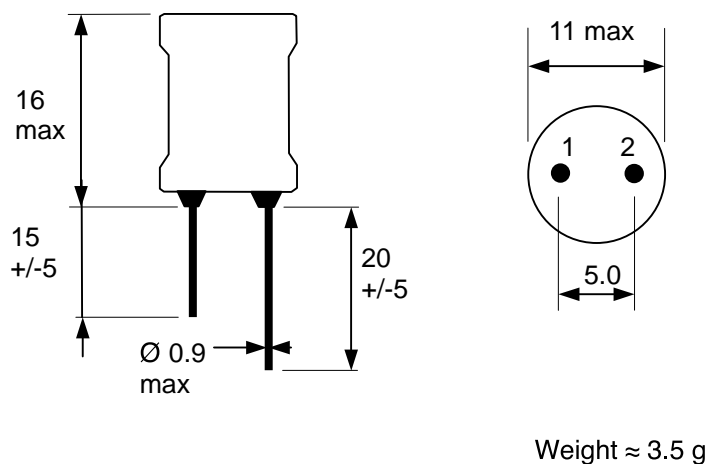

g
A

CURRENT TRANSFORMERS RANGE

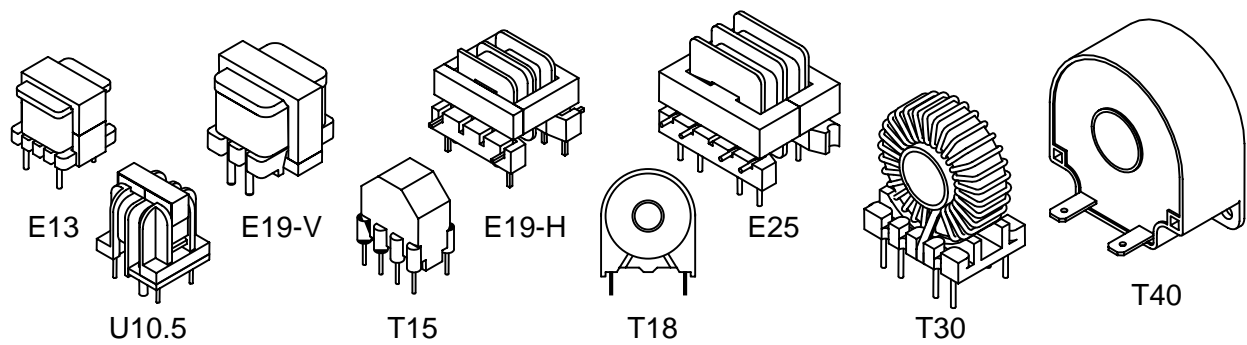

• FOR MAINS AC CURRENT MEASUREMENT - 50 to 400 Hz

MYRRA Part N°	SIZE	Ratio	Current range
PIN PRIMARY - up to 25A			
74521	Size E19-H	Ratio 1 / 1 / 750	Current 10 A / 20 A
74523	Size E19-V	Ratio 1 / 500	Current 15 A
74531	Size E25	Ratio 1 / 1 / 1000	Current 12.5 A / 25 A
74533	Size E25	Ratio 1 / 1000	Current 8 A
74534	Size E25	Ratio 1 / 350	Current 4 A
74561	Size U10.5	Ratio 1 / 2000	Current 8 A
THRU-HOLE PRIMARY - up to 250A			
74503	Size T18	Ratio 1 / 1000	Current 12 A
74504	Size T18	Ratio 1 / 750	Current 10 A
74511	Size T30	Ratio 1 / 1000	Current 60 A
74543, 74544, 74545	Size T40	Ratio 1 / 500	Current 100 A
74546, 74547, 74548	Size T40	Ratio 1 / 1000	Current 250 A

• FOR SWITCH MODE POWER SUPPLIES - 20 to 150kHz

MYRRA Part N°	SIZE	Ratio	Current range
PIN PRIMARY - up to 25A			
74520	Size E19-H	Ratio 1 / 1 / 100	Current 10 A / 20 A
74530	Size E25	Ratio 1 / 1 / 100	Current 12.5 A / 25 A
74550	Size E13	Ratio 1 / 100	Current 10 A
74560	Size U10.5	Ratio 1 / 100	Current 10 A
74562	Size U10.5	Ratio 1 / 100	Current 10 A
74570	Size T15	Ratio 1 / 1 / 50	Current 10 A / 20 A
THRU-HOLE PRIMARY - up to 200A			
74500	Size T18	Ratio 1 / 50	Current 15 A
74501	Size T18	Ratio 1 / 100	Current 25 A
74502	Size T18	Ratio 1 / 200	Current 25 A
74510	Size T30	Ratio 1 / 100	Current 150 A
74540, 74541, 74542	Size T40	Ratio 1 / 100	Current 200 A

TOROIDAL / THRU-HOLE

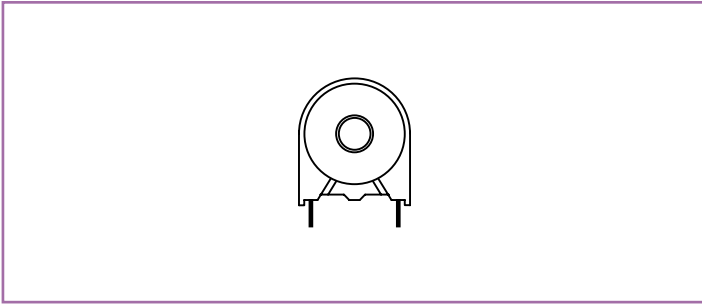

MYRRA Part N°	Sec. Turns	Max Pri. Current A rms	Rsec. Ω max	Lsec. mH min	Pulse Vsec x t max @ Frequency	Sine Vsec max @ Frequency	Typical Load/ Accuracy/ Current
74500	50	15 A	6 Ω	5	175 V. μ S 20 – 200 kHz	15 V 20 – 200 kHz	50 Ω / 1% / 15 A
74501	100	25 A	1.5 Ω	20	350 V. μ S 20 – 100 kHz	25 V 20 – 100 kHz	100 Ω / 1% / 25 A
74502	200	25 A	5 Ω	80	700 V. μ S 20 – 100 kHz	50 V 20 – 100 kHz	200 Ω / 1% / 25 A
74503	1000	12 A	45 Ω	2000	2.5 V.ms 50 Hz	0.15V/ 50 Hz/ 12A 0.6V/ 50 Hz/ 8A	\leq 10 Ω / 2% / 12 A \leq 40 Ω / 2% / 8 A
74504	750	10 A	35 Ω	1100	2.0 V.ms 50 Hz	0.13V/ 50 Hz/ 10A 0.3V/ 50 Hz/ 5A	\leq 10 Ω / 2% / 10 A \leq 40 Ω / 2% / 5 A

Data applies for one primary turn (single passage of primary wire through toroid hole). Sensitivity can be increased for lower currents by winding more than one turn.

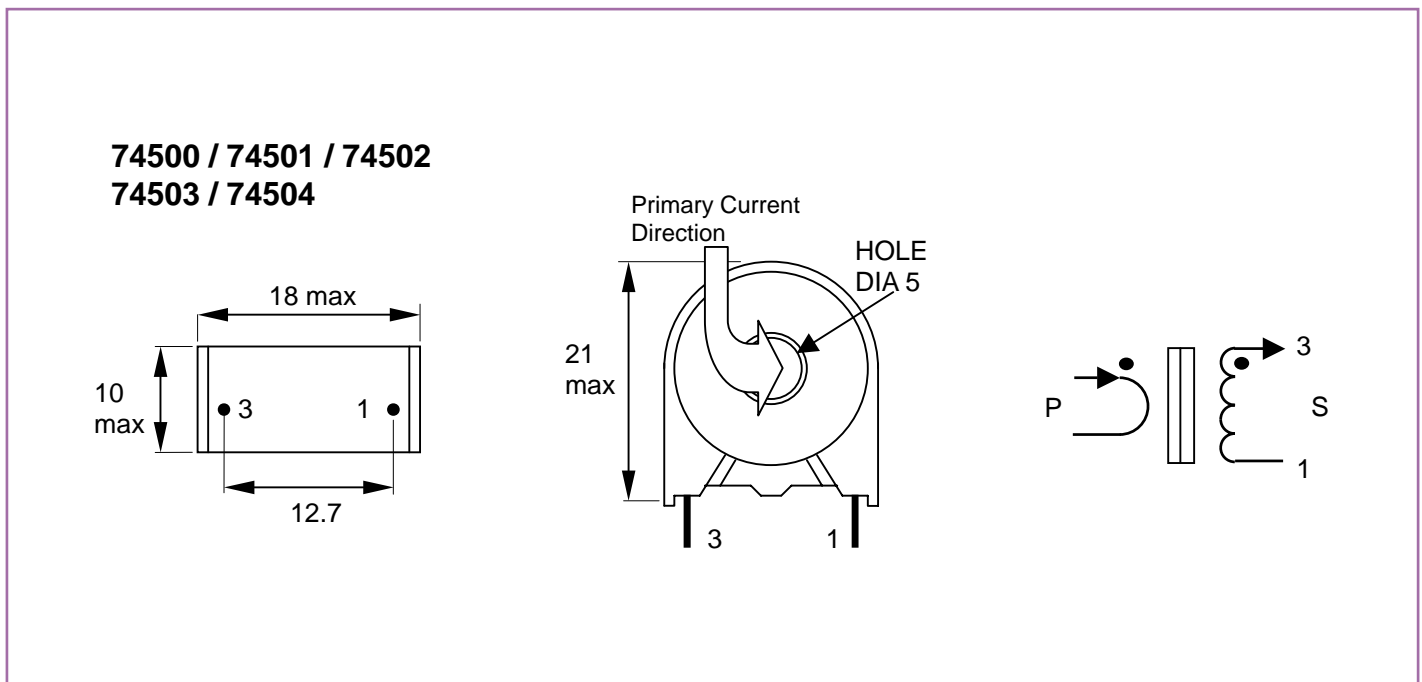



TOROIDAL / THRU-HOLE

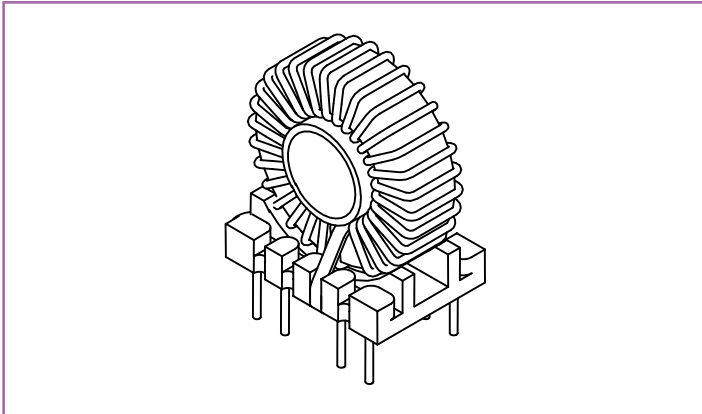

MYRRA Part N°	Sec. Turns	Max Pri. Current A rms	Rsec. Ω max	Lsec. mH min	Pulse Vsec x t max @ Frequency	Sine Vsec max @ Frequency	Typical Load/ Accuracy/ Current
74510	100	150 A	0.25Ω	40	1 V.ms/ 20 kHz 700 V μs/ 100 kHz	50 V/ 20 kHz 80 V/ 100 kHz	1 - 20 Ω / 1%
74511	1000	60 A	32 Ω	4000	10 V.ms/ 50 Hz	0.6 V/ 50 Hz/ 60 A 1 V/ 50 Hz/ 40 A	≤ 10 Ω / 1% / 60 A ≤ 20 Ω / 1% / 40 A

Data applies for one primary turn (single passage of primary wire through toroid hole). Sensitivity can be increased for lower currents by winding more than one turn. Models with 50, 100, 200 turns are designed for switch-mode power conversion (up to 200 kHz). Models with 500 and 1000 turns are designed for Mains current measurement (50 to 400 Hz).

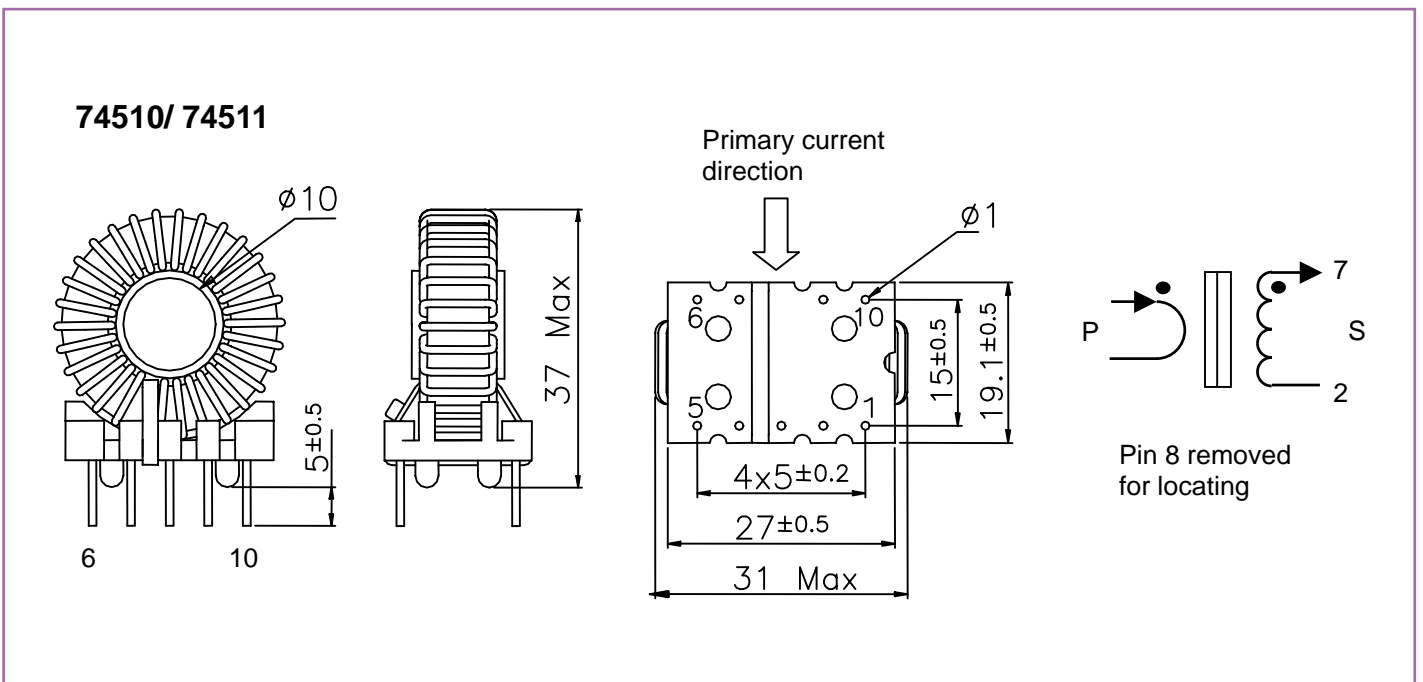

HF
A

CURRENT TRANSFORMERS
PIN PRIMARY TYPES

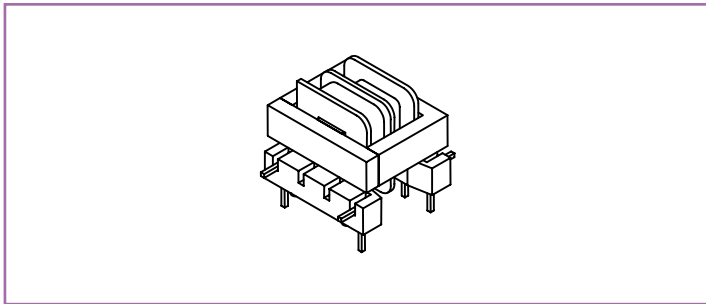

FOR SWITCH MODE POWER SUPPLIES - 20 to 150 kHz								
MYRRA Part N°	Ratio	Max Pri. Current A rms	Rsec. Ω max	Lsec. mH min	Pulse Vsec x t max	Sine Vsec rms max	Typical Load/ Accuracy/ Current	Insulation Voltage P/ S
74520	1/1/100	20 A parallel 10 A serie	1.5	8	400 V.µs	50 Vrms	10 – 100 Ω / 1% / 10 A	2500 V

FOR MAINS AC CURRENT MEASUREMENT - 50 to 400 Hz								
MYRRA Part N°	Ratio	Max Pri. Current A rms	Rsec. Ω max	Lsec. mH min	Pulse Vsec x t max	Sine Vsec rms max	Typical Load/ Accuracy/ Current	Insulation Voltage P/ S
74521	1/1/750	20 A parallel 10 A serie	57	300	15 V.ms	3 Vrms	≤ 75 Ω / 4% / 20 A	2500 V

SAFETY :

These products are only composed of UL approved materials.
These products have a construction conform to CEI950, CEI335, CEI61558 for Basic insulation (3 mm creepage distance)

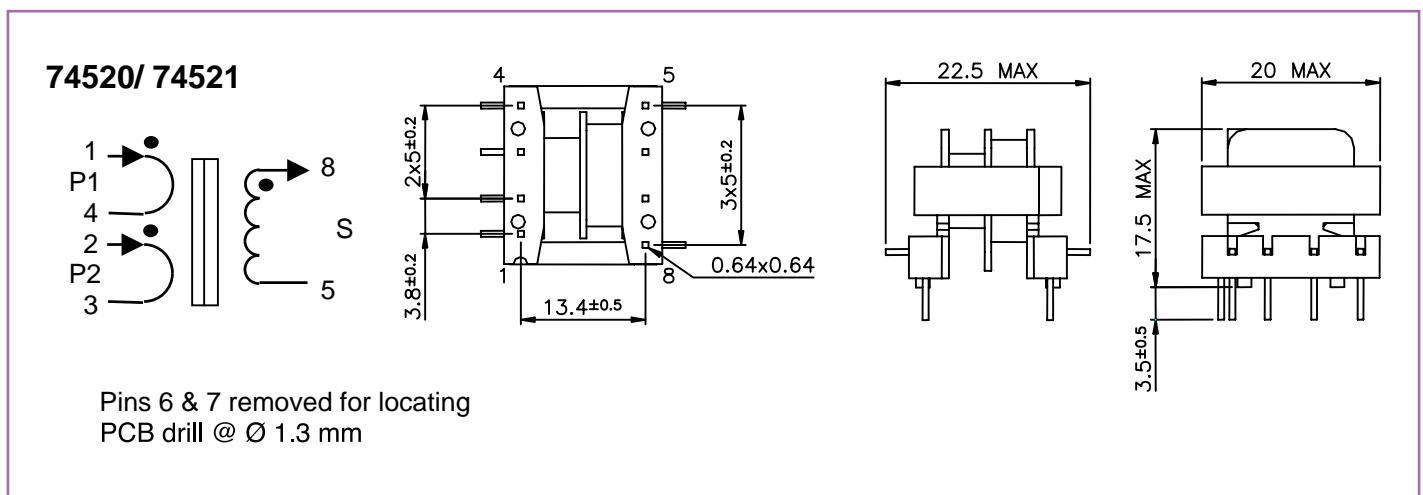

HG

CURRENT TRANSFORMERS
PIN PRIMARY TYPES

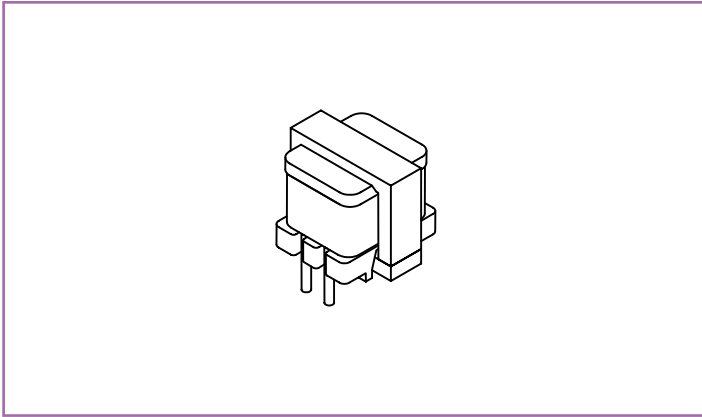

FOR MAINS AC CURRENT MEASUREMENT - 50 to 400 Hz								
MYRRA Part N°	Ratio	Max Pri. Current A rms	Rsec. Ω max	Lsec. mH min	Pulse Vsec x t max	Sine Vsec rms max	Typical Load/ Accuracy/ Current	Insulation Voltage P/ S
74523	1/ 500	15 A	155	670	30 V.ms	6 Vrms	≤ 50 Ω / 2% / 15 A ≤ 200 Ω / 5% / 10 A	1500 V

SAFETY :

This product is only composed of UL approved materials.

This product has a construction conform to CEI950, CEI335, CEI61558 for Functional insulation

74523

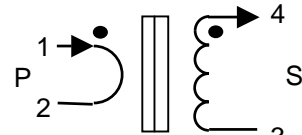

Pins 6 & 7 removed for locating PCB drill @ Ø 1.2 & 1.8 mm

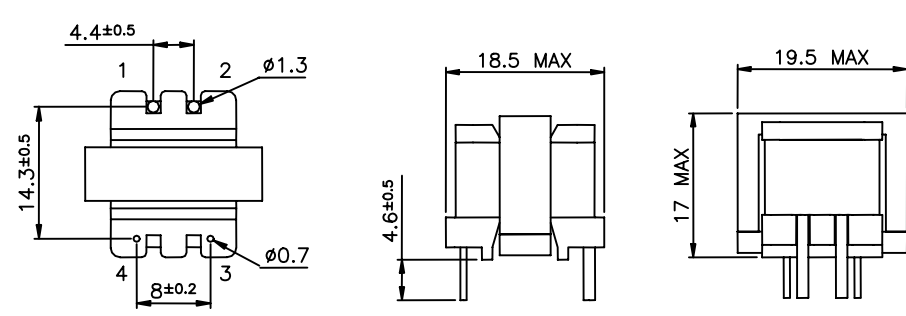

CURRENT TRANSFORMERS
PIN PRIMARY TYPES

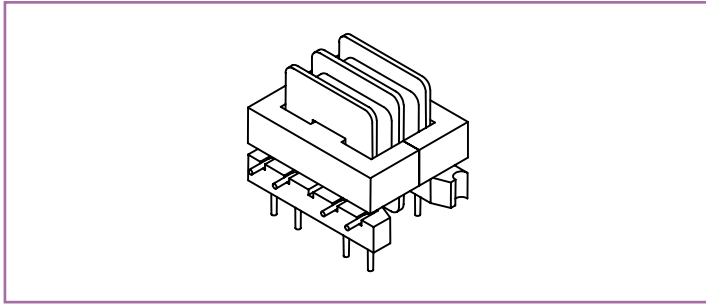

FOR SWITCH MODE POWER SUPPLIES - 20 to 150 kHz

MYRRA Part N°	Ratio	Max Pri. Current A rms	Rsec. Ω max	Lsec. mH min	Pulse Vsec x t max	Sine Vsec rms max	Typical Load/ Accuracy/ Current	Insulation Voltage P/ S
74530	1/1/100	25 A parallel 12.5 A serie	1	10	600 V.µs	80 Vrms	10 - 100 Ω / 1% / 25 A	2500 V

FOR MAINS AC CURRENT MEASUREMENT - 50 to 400 Hz

MYRRA Part N°	Ratio	Max Pri. Current A rms	Rsec. Ω max	Lsec. mH min	Pulse Vsec x t max	Sine Vsec rms max	Typical Load/ Accuracy/ Current	Insulation Voltage P/ S
74531	1/1/1000	25 A parallel 12.5 A serie	90	4 H	8 V.ms	1.6 Vrms	≤ 50 Ω / 2% / 20 A	2500 V
74533	1/ 1000	8 A	360	17 H	15 V.ms	3 Vrms	≤ 200 Ω / 1% / 8 A ≤ 500 Ω / 1.5% / 5 A	2500 V
74534	1/ 350	4 A	380	19 H	15 V.ms	3 Vrms	≤ 100 Ω / 1% / 4 A ≤ 500 Ω / 1% / 2 A	2500 V

SAFETY :

These products are only composed of UL approved materials.
These products have a construction conform to CEI950, CEI335, CEI61558 for Basic insulation (3 mm creepage distance)

74530/ 74531

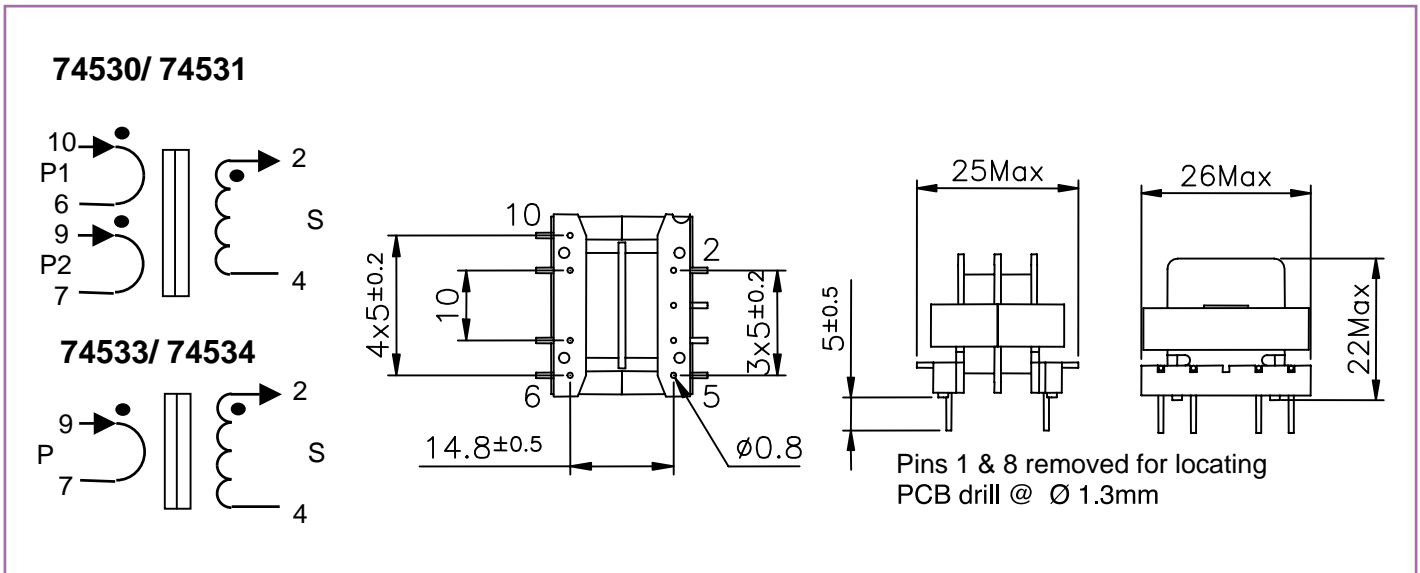

74533/ 74534

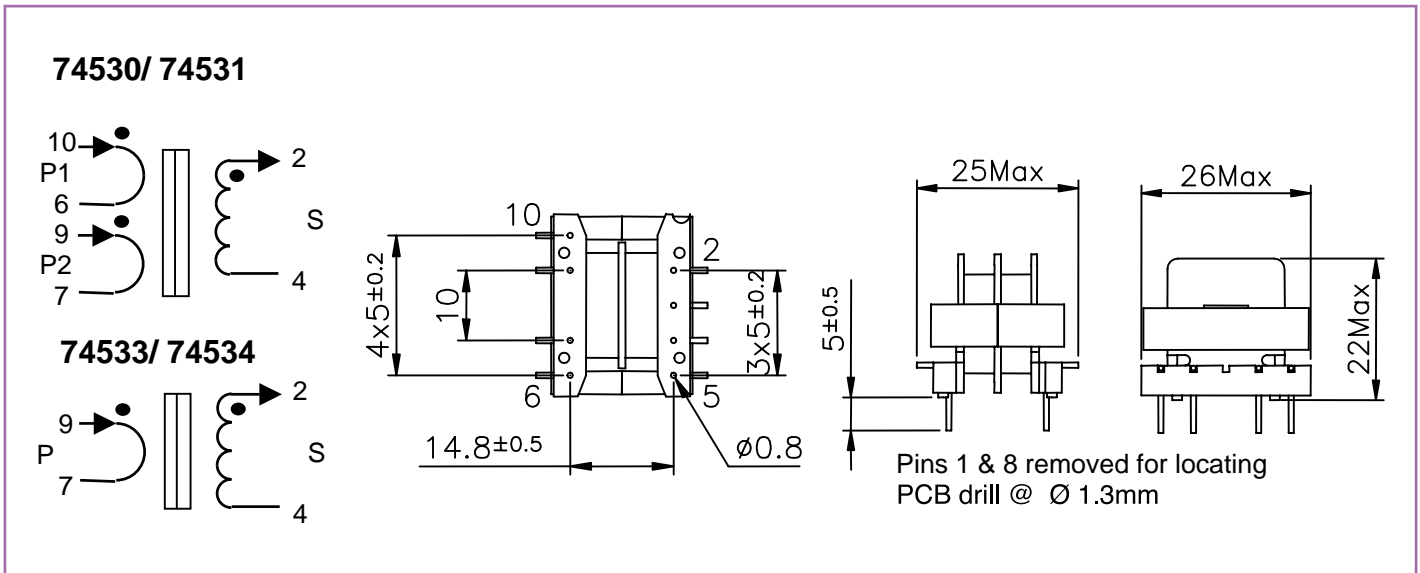

Pins 1 & 8 removed for locating PCB drill @ Ø 1.3mm

CURRENT TRANSFORMERS



TOROIDAL / THRU-HOLE

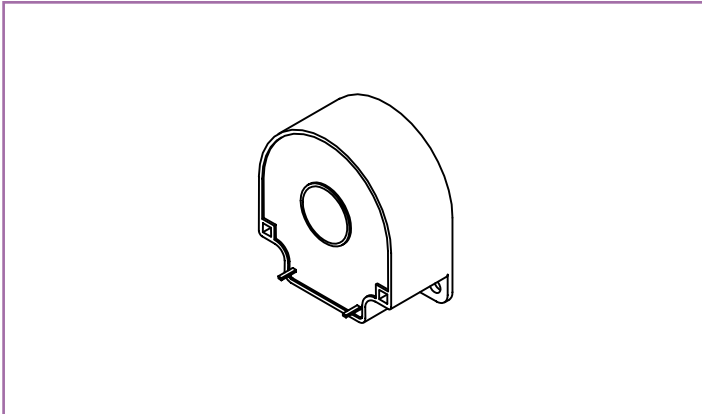

MYRRA Part N°	Sec. Turns	Max Pri. Current A rms	Rsec. Ω max	Lsec. mH min	Pulse Vsec x t max @ Frequency	Sine Vsec max @ Frequency	Typical Load/ Accuracy/ Current
74540	100	200 A	0.35Ω	50	2 V.ms/ 20 kHz 1 V.ms/ 100 kHz	150 V/ 20 kHz 150 V/ 100 kHz	1..20 Ω / 1%
74543	500	100 A	6.5 Ω	1250	10 V.ms/ 50 Hz	0.7 V/ 50Hz/ 100 A 1.2 V/ 50Hz/ 60 A	≤ 3 Ω / 1% / 100 A ≤ 10 Ω / 1% / 60 A
74546	1000	250 A	22 Ω	8000	100 V.ms/ 50 Hz	15 V/ 50 Hz/ 250 A	≤ 50 Ω / 1% / 250 A

Data applies for one primary turn (single passage of primary wire through toroid hole). Sensitivity can be increased for lower currents by winding more than one turn.

74540/ 74543/ 74546 Pin type (for PCB)

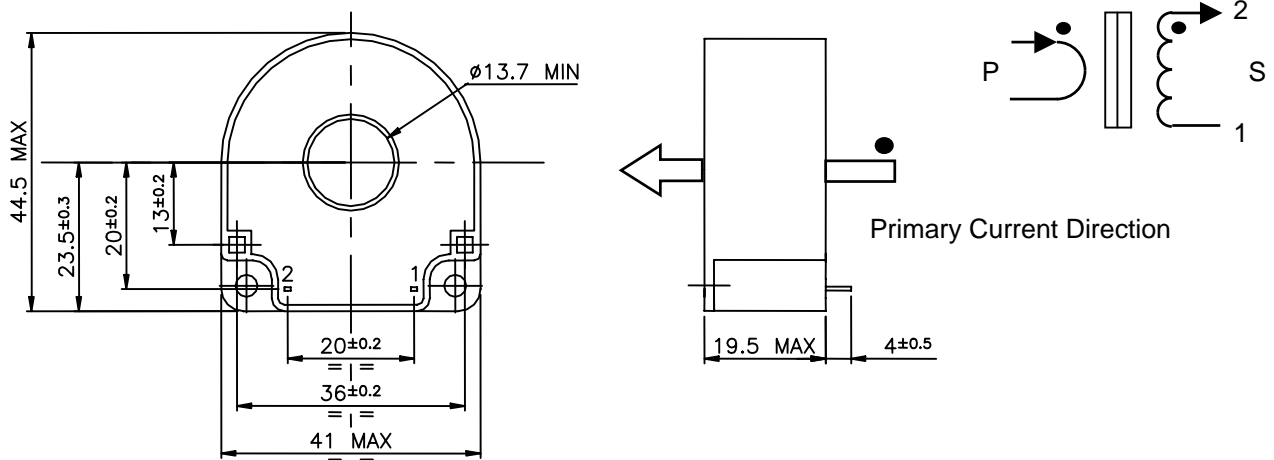

H

TOROIDAL / THRU-HOLE

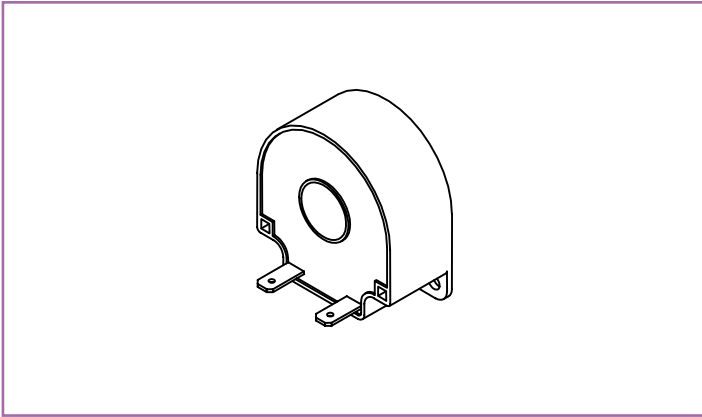

MYRRA Part N°	Sec. Turns	Max Pri. Current A rms	Rsec. Ω max	Lsec. mH min	Pulse Vsec x t max @ Frequency	Sine Vsec max @ Frequency	Typical Load/ Accuracy/ Current
74541	100	200 A	0.35 Ω	50	2 V.ms/ 20 kHz 1 V.ms/ 100 kHz	150 V/ 20 kHz 150 V/ 100 kHz	1..20 Ω / 1%
74544	500	100 A	6.5 Ω	1250	10 V.ms/ 50 Hz	0.7 V/ 50Hz/ 100 A 1.2 V/ 50Hz/ 60 A	$\leq 3 \Omega$ / 1% / 100 A $\leq 10 \Omega$ / 1% / 60 A
74547	1000	250 A	22 Ω	8000	100 V.ms/ 50 Hz	15 V/ 50 Hz/ 250 A	$\leq 50 \Omega$ / 1% / 250 A

Data applies for one primary turn (single passage of primary wire through toroid hole). Sensitivity can be increased for lower currents by winding more than one turn.

74541/ 74544/ 74547 FASTON Connectors

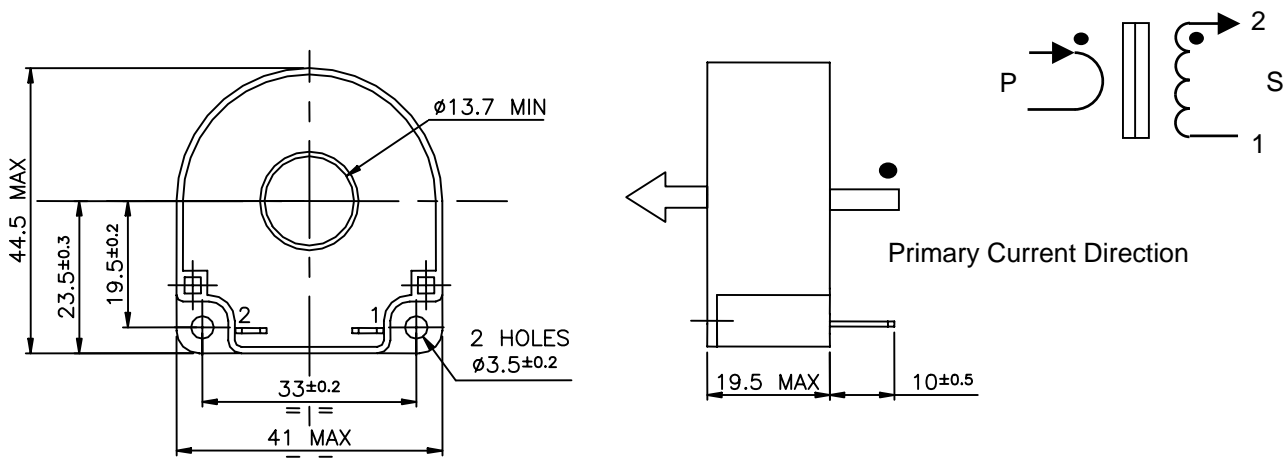

H
A

TOROIDAL / THRU-HOLE

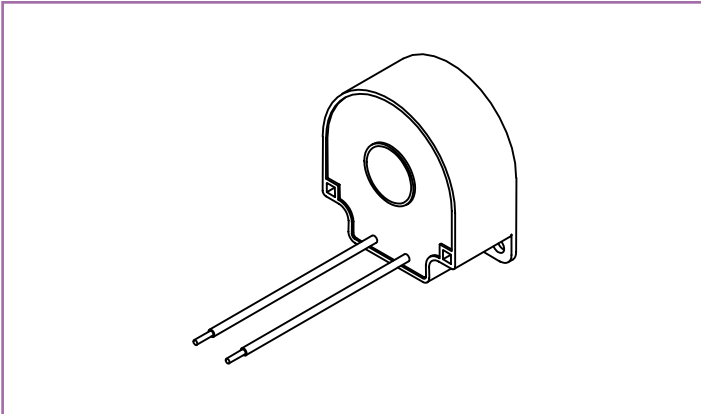

MYRRA Part N°	Sec. Turns	Max Pri. Current A rms	Rsec. Ω max	Lsec. mH min	Pulse Vsec x t max @ Frequency	Sine Vsec max @ Frequency	Typical Load/ Accuracy/ Current
74542	100	200 A	0.35Ω	50	2 V.ms/ 20 kHz 1 V.ms/ 100 kHz	150 V/ 20 kHz 150 V/ 100 kHz	1..20 Ω / 1%
74545	500	100 A	6.5 Ω	1250	10 V.ms/ 50 Hz	0.7 V/ 50Hz/ 100 A 1.2 V/ 50Hz/ 60 A	≤ 3 Ω / 1% / 100 A ≤ 10 Ω / 1% / 60 A
74548	1000	250 A	22 Ω	8000	100 V.ms/ 50 Hz	15 V/ 50 Hz/ 250 A	≤ 50 Ω / 1% / 250 A

Data applies for one primary turn (single passage of primary wire through toroid hole). Sensitivity can be increased for lower currents by winding more than one turn.

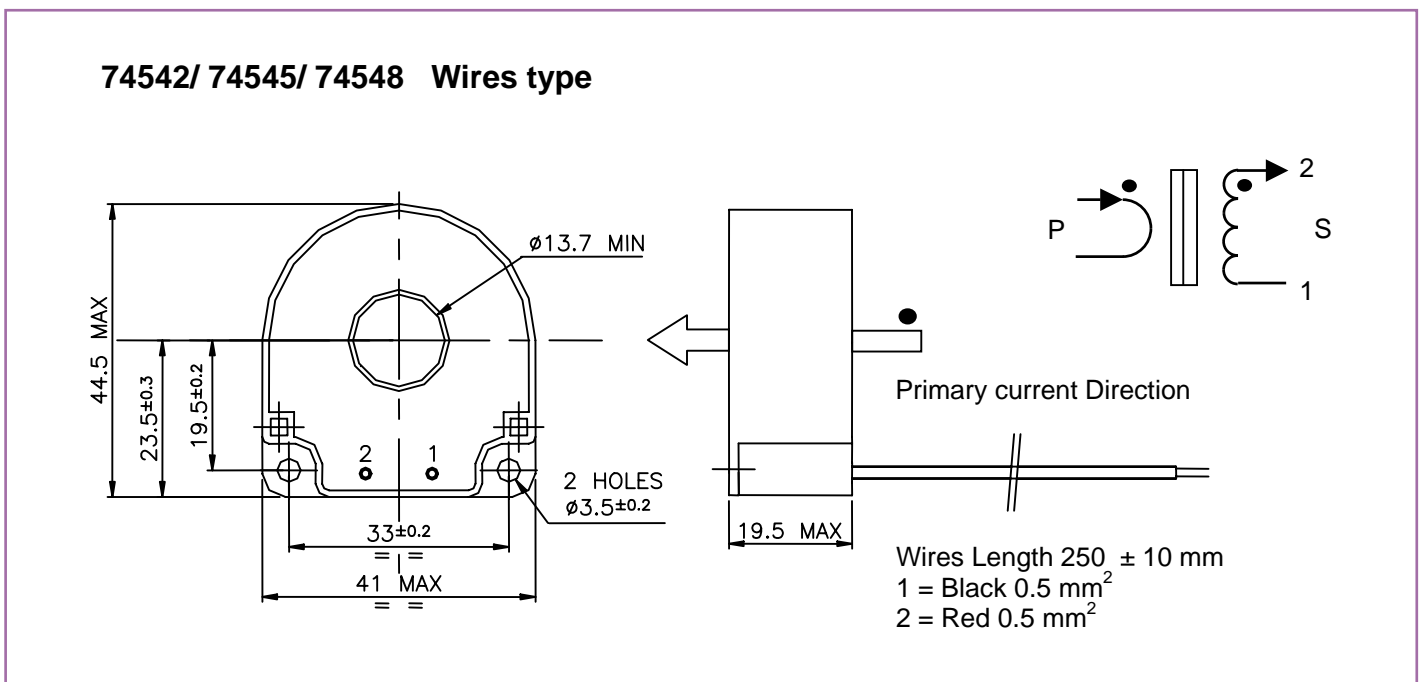

H

PIN PRIMARY TYPES

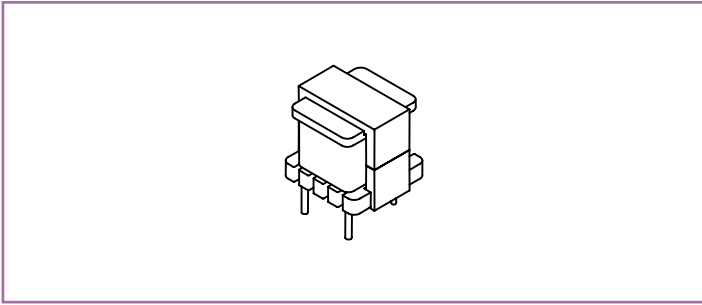

FOR SWITCH MODE POWER SUPPLIES - 20 to 150 kHz								
MYRRA Part N°	Ratio	Max Pri. Current A rms	Rsec. Ω max	Lsec. mH min	Pulse Vsec x t max	Sine Vsec rms max	Typical Load/ Accuracy/ Current	Insulation Voltage P/ S
74550	1/ 100	10	2.3	6	250 V $\cdot\mu$ s	40 Vrms	10 – 100 Ω / 1% / 10 A	1500 V

SAFETY :

This product is only composed of UL approved materials.

This product has a construction conform to CEI950, CEI335, CEI61558 for functional insulation

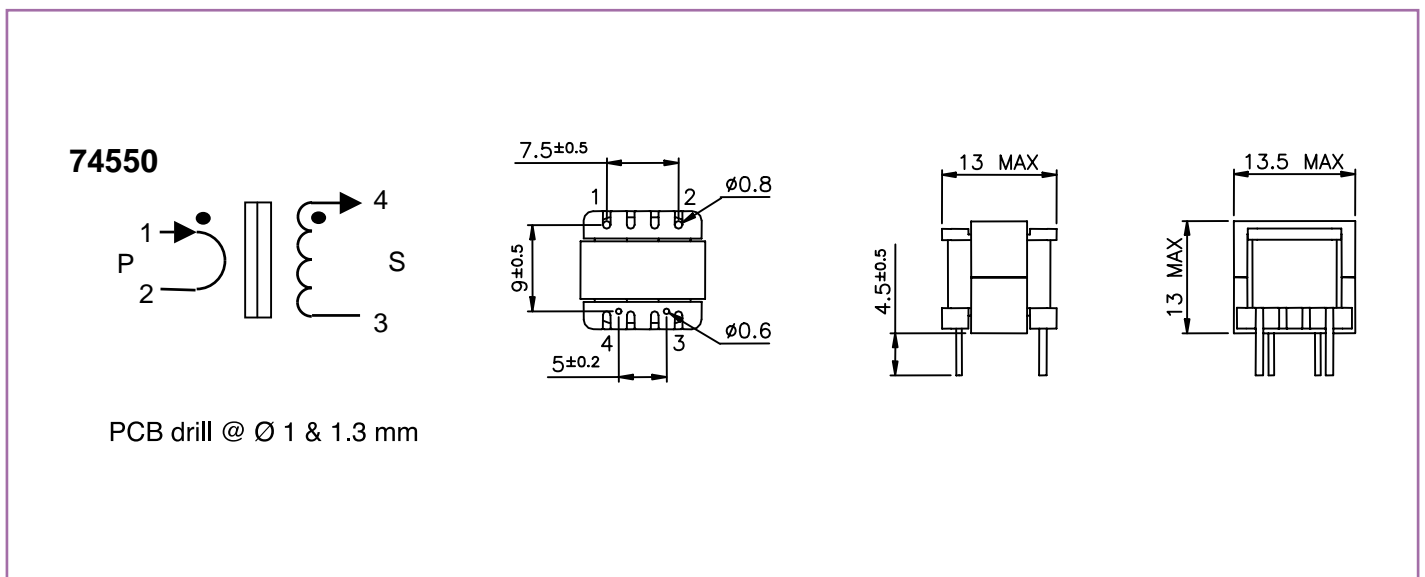

PIN PRIMARY TYPES

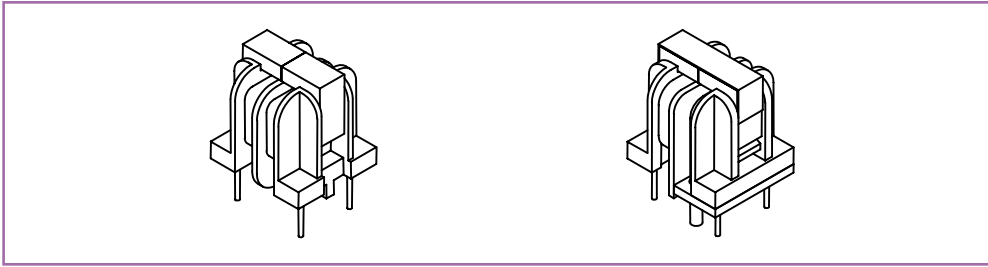

FOR SWITCH MODE POWER SUPPLIES - 20 to 150 kHz								
MYRRA Part N°	Ratio	Max Pri. Current A rms	Rsec. Ω max	Lsec. mH min	Pulse Vsec x t max	Sine Vsec rms max	Typical Load/ Accuracy/ Current	Insulation Voltage P/ S
74560	1/ 100	10	1.1	12	300 V. μ s	25 Vrms	5 – 50 Ω / 1% / 10 A	4000 V
74562	1/ 100	25	1.1	12	300 V. μ s	25 Vrms	5 – 50 Ω / 1% / 25 A	4000 V

FOR MAINS AC CURRENT MEASUREMENT - 50 to 400 Hz								
MYRRA Part N°	Ratio	Max Pri. Current A rms	Rsec. Ω max	Lsec. mH min	Pulse Vsec x t max	Sine Vsec rms max	Typical Load/ Accuracy/ Current	Insulation Voltage P/ S
74561	1/ 2000	8 A	400	4.5 H	5 V.ms	1 Vrms	\leq 100 Ω / 2% / 6 A	4000 V

SAFETY :

These products are only composed of UL approved materials.

These products have a construction conform to CEI950, CEI335, CEI61558 for Reinforced insulation

74560, 74561 : 8 mm creepage distance

74562 : 6 mm creepage distance

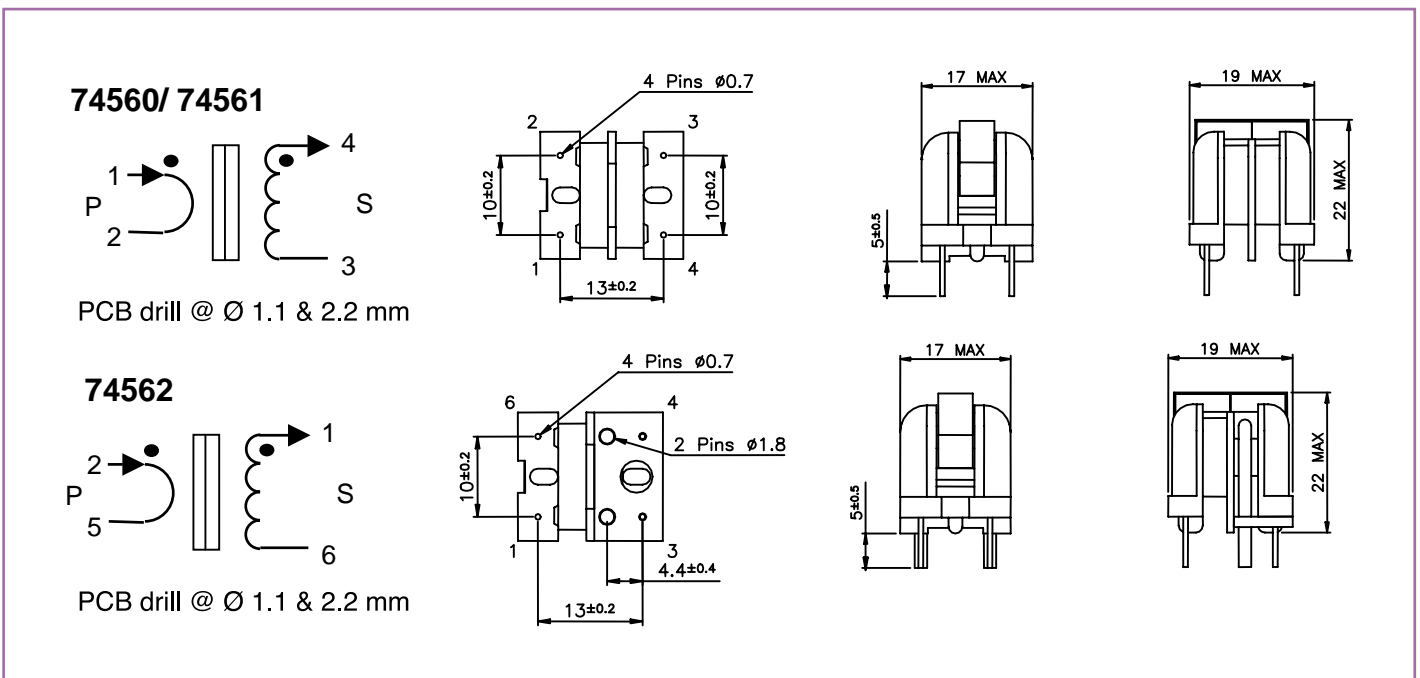

PIN PRIMARY TYPES

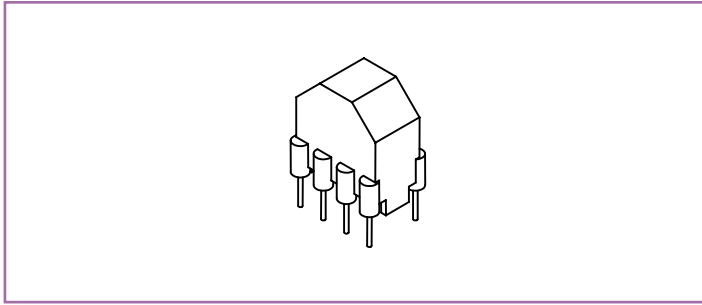

FOR SWITCH MODE POWER SUPPLIES - 20 to 150 kHz								
MYRRA Part N°	Ratio	Max Pri. Current A rms	Rsec. Ω max	Lsec. mH min	Pulse Vsec x t max	Sine Vsec rms max	Typical Load/ Accuracy/ Current	Insulation Voltage P/ S
74570	1/1/50	20 A parallel 10 A serie	0.32	9	150 V.μs	12 Vrms	5 – 25 Ω / 1% / 20 A	4000 V

SAFETY :

This product is only composed of UL approved materials.

This product has a construction conform to CEI950, CEI335, CEI61558 for Reinforced insulation (8 mm creepage distance)

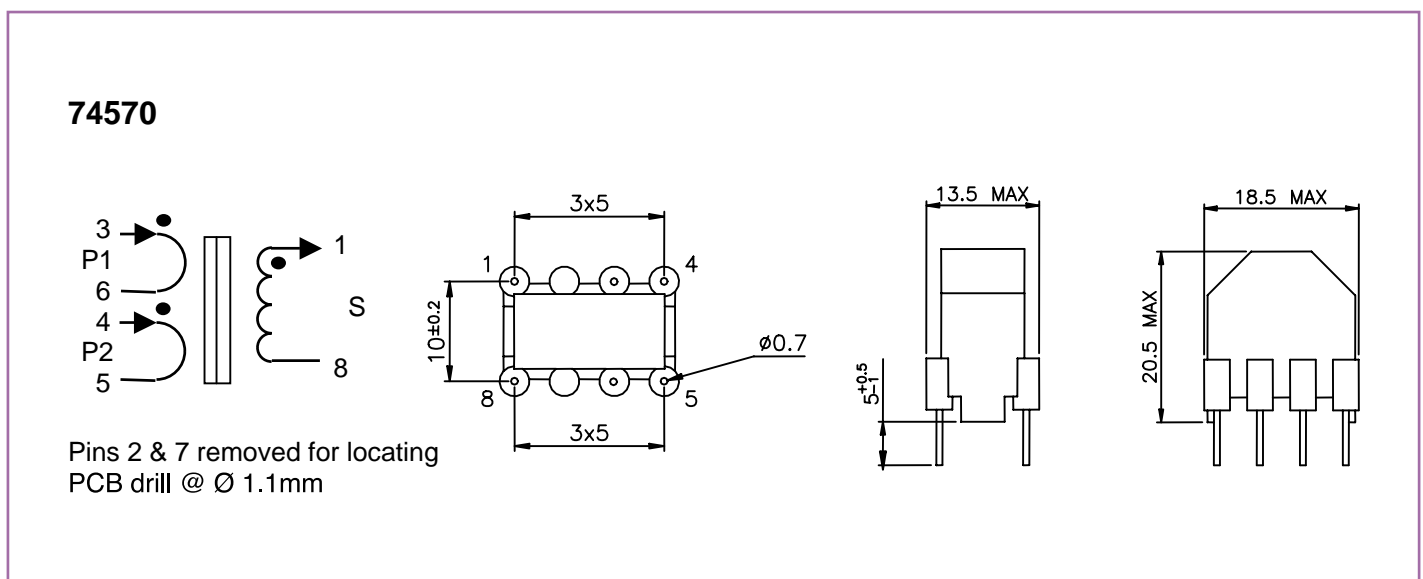

I €

PULSE TRANSFORMERS RANGE

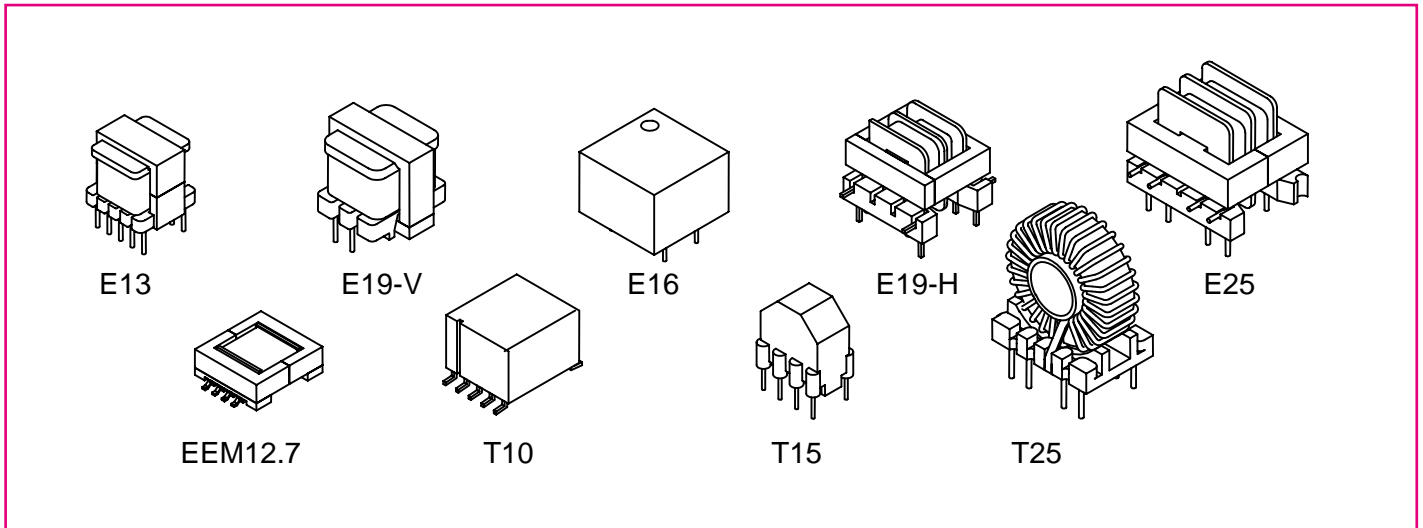

To be used for MOSFET or IGBT Drive, SCR triggering, DC/DC power conversion, Voltage isolation.

MYRRA Part N°	SIZE	Ratio	
74600	Size T15	Ratio 1 / 1 / 1	Low stray inductance
74610	Size T25	Ratio 1 / 1 / 1	Low stray inductance
74611	Size T25	Ratio 1 / 1 / 1	Low stray inductance
74620	Size E19-H	Ratio 1 / 1 / 1	Low coupling capacitance
74620	Size E19-H	Ratio 3 / 1 / 1	Low coupling capacitance
74630	Size E25	Ratio 1 / 1 / 1	Low coupling capacitance
74631	Size E25	Ratio 3 / 1 / 1	Low coupling capacitance
74640	Size E19-V	Ratio 1 / 5	For voltage step-up
74641	Size E19-V	Ratio 1 / 10	For voltage step-up
74650	Size E13	Ratio 1 / 1 / 1	Small size
74710	Size E16	Ratio 1 / 1	Low coupling capacitance
74660	Size EEM12.7	Ratio 1CT / 1.3CT	SMD
74661	Size EEM12.7	Ratio 1CT / 1CT	SMD, for DC/DC converter
74670	Size T10	Ratio 1CT / 1.3	SMD, Low stray inductance

IF

PULSE TRANSFORMERS TOROID TYPES

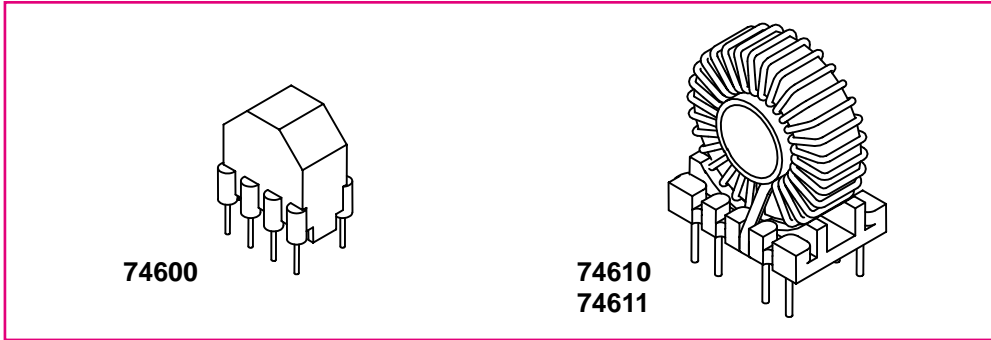

MYRRA Part N°	Ratio P/S1/S2	L pri. +/-30%	Current / winding Arms max	Resistance / winding Ω max	Pulse E x t V.µs max	square V / kHz max	C P/S pF max	Lleak P/S max	Insulation Voltage	
									P/S	S1/S2
74600	1 / 1 / 1	4 mH	0.6	0.35	150 V.µs	0.4	20 pF	1.5 µH	4 kV	4 kV
74610	1 / 1 / 1	0.9 mH	1.7	0.07	150 V.µs	0.4	20 pF	0.8 µH	4 kV	4 kV
74611	1 / 1 / 1	3.6 mH	1.2	0.14	300 V.µs	0.8	30 pF	2.0 µH	4 kV	4 kV

- Toroid core gives best coupling, lowest leakage inductance, fast rise time.
- SAFETY :**
- These products are only composed of UL-V0 approved materials.
- Insulation test voltage : 4000 Vrms
- This product has a construction conform to CEI950, CEI335, CEI61558 for Reinforced insulation (8 mm creepage distance)

74600 Size T15

Pins 2 & 7 removed for locating PCB drill @ Ø 1.1mm Weight ~ 6 g

74610 - 74611 Size T25

Pin 8 removed for locating PCB drill @ Ø 1.3mm Weight ~ 18 g

PULSE TRANSFORMERS E19-H / E25 TYPES

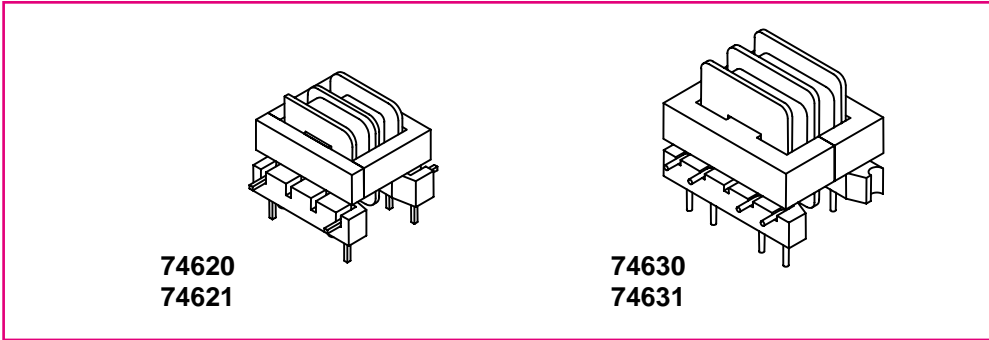

MYRRA Part N°	Ratio P/S1/S2	L pri. +/-30%	Current / winding Arms max	Resistance / winding Ω max	Pulse E x t V.µs max	square V / kHz max	C P/S pF max	Lleak P/S max	Insulation Voltage	
									P/ S	S1/S2
74620	1 / 1 / 1	3.2 mH	0.5	1.0	350 V.µs	0.6	5 pF	70 µH	2.5 kV	1.5 kV
74621	3 / 1 / 1	17 mH	0.3	2.0	800 V.µs	1.5	5 pF	400 µH	2.5 kV	1.5 kV
74630	1 / 1 / 1	2 mH	1	0.4	500 V.µs	0.8	7 pF	60 µH	2.5 kV	1.5 kV
74631	3 / 1 / 1	10 mH	0.45	0.8	1000 V.µs	1.7	7 pF	300 µH	2.5 kV	1.5 kV

- Principally dedicated to SCR triggering
- Designed for minimum coupling capacitance

SAFETY :

These products are only composed of UL-V0 approved materials.

74620 - 74621 Size E19-H

Pin 1 removed for locating PCB drill @ Ø 1.3mm Weight ≈ 12 g

74630 - 74631 Size E25

Pins 1 & 8 removed for locating PCB drill @ Ø 1.3mm Weight ≈ 20 g

LOW FREQUENCY PULSE TRANSFORMERS for voltage step-up

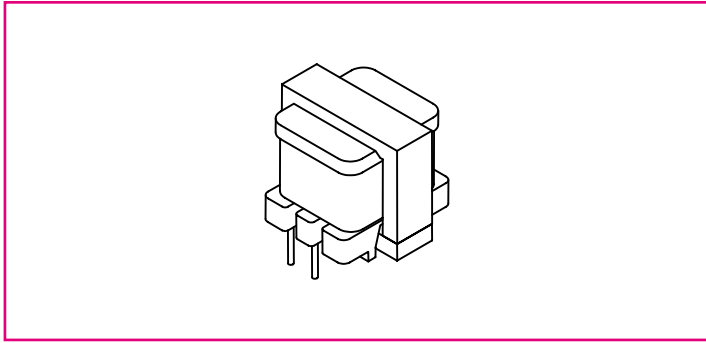

MYRRA Part N°	Ratio P/S	L pri. +/-30%	Current Arms max	Resistance Ω max	Pulse Vsec . t max	Sine Vsec. max	Insulation Voltage P/ S
74640	1 / 5	11 mH	Pri : 0.5 Sec : 0.1	Pri : 1.0 Sec : 31	16 V.ms	4 Vrms / 50 Hz 50 Vrms / 5 kHz	1500
74641	1 / 10	11 mH	Pri : 0.4 Sec : 0.04	Pri : 1.8 Sec : 80 Ω	33 V.ms	8 Vrms / 50 Hz 100 Vrms / 5 kHz	1500

SAFETY :

- These products are only composed of UL-V0 approved materials.

74640-74641 Size E19-V

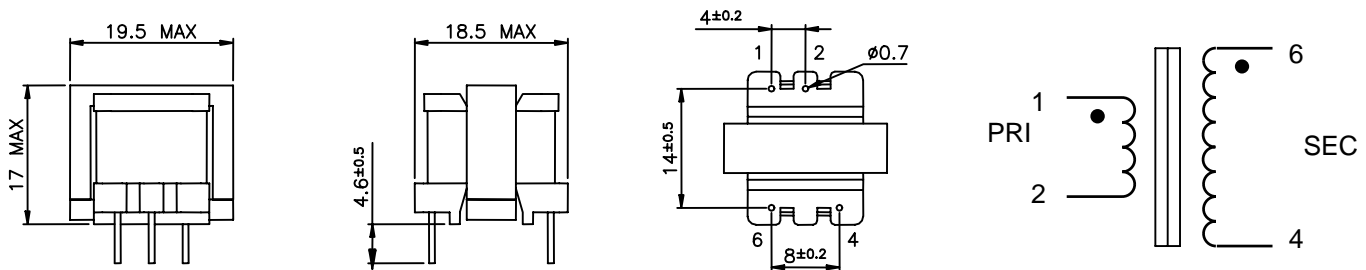

Pins 3 & 5 removed for locating PCB drill @ \varnothing 1.1mm Weight \approx 14 g

PULSE TRANSFORMERS E13 - E16



MYRRA Part N°	Ratio P/S1/S2	L pri.	Current / winding Arms max	Resistance / winding Ω max	Pulse E x t V.µs max	square V / kHz max	C P/S pF max	Lleak P/S max	Insulation Voltage	
									P / S	S1/S2
74650	1 / 1 / 1	500 µH +/-30%	0.6	0.28	120 V.µs	20V/ 100kHz	12 pF	2 µH	1.5 kV	1.5 kV
74710	1 / 1	2 mH +/-40%	0.6	0.6	300 V.µs	50V/ 100kHz	6 pF	44 µH	4 kV	

- 74650 is principally designed for Mosfet drive in SMPS (Forward or Bridge converters)
- 74710 is principally designed for SCR Triggering

SAFETY :

These products are only composed of UL-V0 approved materials.

The product 74710 has a construction conform to CEI950, CEI335, CEI61558 for Reinforced insulation (8 mm creepage distance)

74650 Size E13

Pin 8 removed for locating PCB drill @ Ø 1.1mm Weight ≈ 4 g

74710 Size E16

PCB drill @ Ø 1.1mm Weight ≈ 8 g

PULSE TRANSFORMERS SMD TYPES



MYRRA Part N°	Ratio P / S	L pri.	Current / winding max	Resistance / winding Ω max	Pulse E x t max P1 or P2	square V / kHz max P1 or P2	C P/S pF max	Lleak P/S max	Insulation Voltage
									P / S
74660	1+1 / 1.3+1.3	240 μ H +/-30%	0.2 Arms	0.9	50 V. μ s	15V / 100 – 500kHz	20 pF	0.35 μ H	0.5 kV
74661	1+1 / 1+1	10 μ H +/-10%	3 Apeak / 0.5 Arms	0.2	30 V. μ s	0.05 V / kHz / 100 – 400kHz	20 pF	0.2 μ H	0.5 kV
74670	1+1 / 1.3	220 μ H +/-30%	0.4 Arms	0.25	15 V. μ s	0.03 V / kHz / 100 – 500kHz	12 pF	0.4 μ H	4 kV

- 74660 can be used in association with MAXIM MAX250 or MAX253
- 74661 can be used in association with LINEAR TECHNOLOGY LT1424
- 74660 can be used in association with MAXIM MAX485

SAFETY :

These products are only composed of UL-V0 approved materials.

74660 – 74661 Size EEM12.7

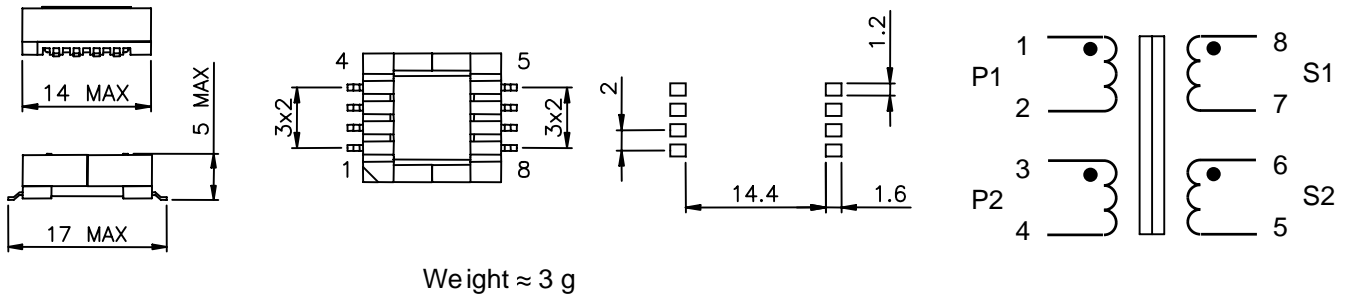

74670 – 74714 Size T10

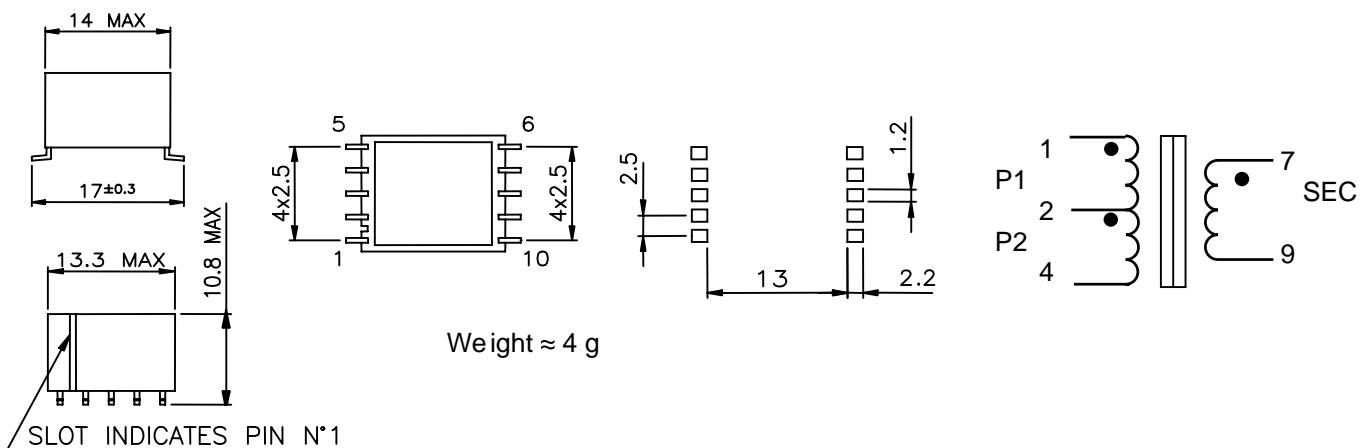

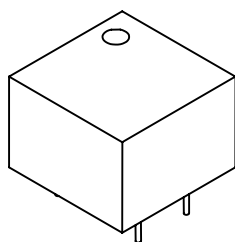

74710

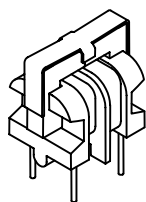

74711

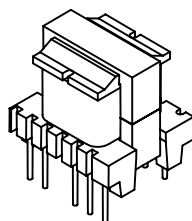

74712

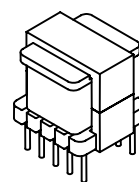

74713

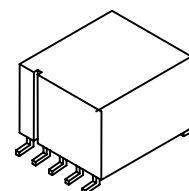

74714 - 74715

- Designed for coupling signals to power line
- Adapted for use with Modem Circuits : ST7537 or TDA5051 or IC/SS
- Models 74710 and 74711 are designed for resonance at 132.5 kHz between the series coupling capacitor (33nF) and the transformer leakage inductance.
- Models 74712 and 74713 are designed for resonance at 132.5 kHz between the capacitor (6.8nF or 10nF) in parallel with the primary magnetizing inductance.

MYRRA Part N°	Primary Inductance (μH)	Leakage Inductance (μH)	Resistance per winding P / S (max)	Frequency range	Turns ratio P / S	Max Sec. current (50-60Hz rms)	Insulation (Vrms)	Size
74710	2.0 mH +/-40% (1 - 3)	44 +/-7%	0.6 Ω / 0.6 Ω	10 – 450kHz	1 / 1	10 mA	4000	EF16-H-4P
74711	2.9 mH +/-40% (1 -2)	44 +/-7%	1 Ω / 1 Ω	10 – 200kHz	1 / 1	4 mA	1500	U9.8-4P
74712	212 μH +/-10% (2 - 5)	< 5 μH (2 - 5)	0.8 Ω / 0.04 Ω	10kHz – 1MHz	5+1 / 1	500 mA	4000	E16-V-10P
74713	144 μH +/-10% (2 - 5)	< 5μH	0.5 Ω / 0.5 Ω	10 – 450kHz	5+1 / 5+1	200 mA	1500	E13-V-10P
74714	1.3 mH +/-40% (2 - 4)	< 0.5μH	0.2 Ω / 0.2 Ω	10 – 200kHz	1 / 1	4 mA	5500	T10-SMD
74715	3.0μH +/-25% (2 - 4)	< 0.1 μH	0.06 Ω / 0.1 Ω	1 – 20 MHz	2 / 1+1	200 mA	4000	T10-SMD

Safety :

All products meet IEC 60950 and IEC60558 requirements

74710, 74714 and 74715 : reinforced insulation, creepage distance > 8 mm

74712 : reinforced insulation, creepage distance > 6 mm

74711, 74713 : Fonctionnal insulation

74710

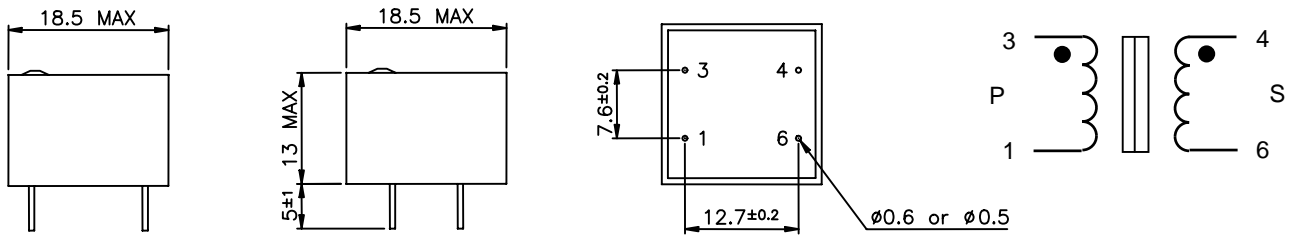

74711

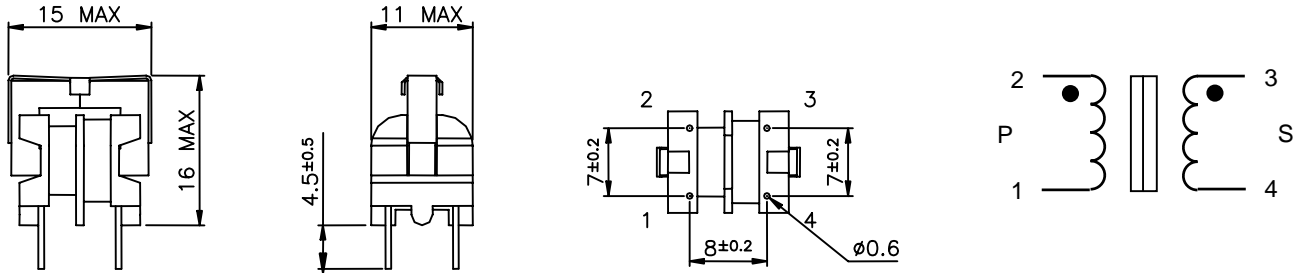

74712

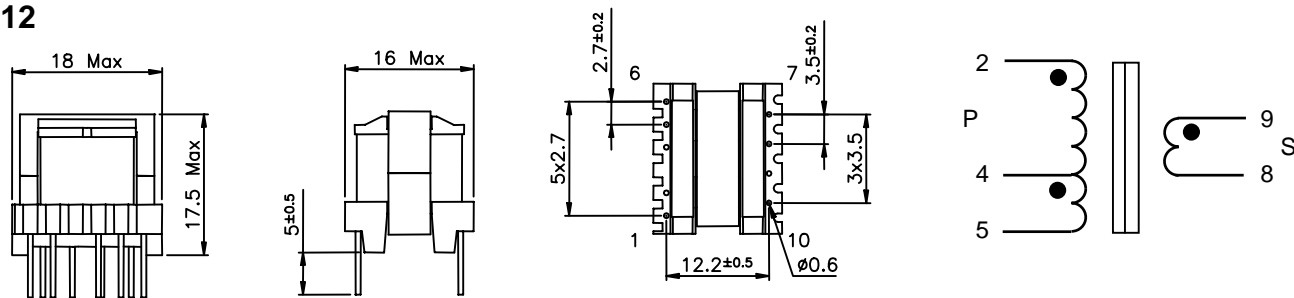

74713

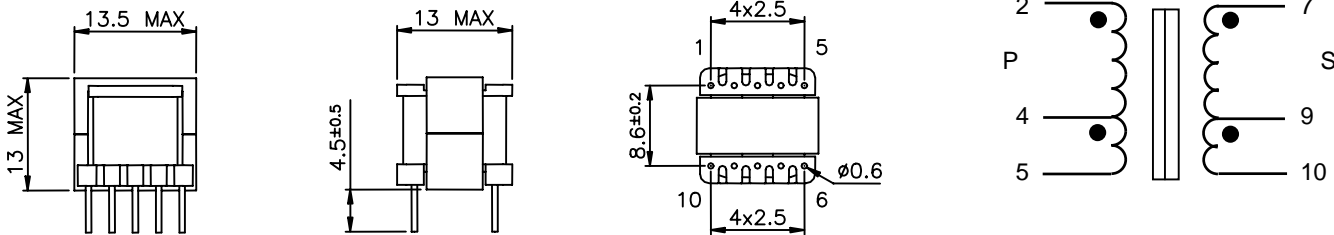

74714, 74715

