

medical

VPU15 series

V1.1

The VPU15 series of AC/DC switching mode power supplies provide 15 Watts of continuous output power . All supplies are UL94V-1 min compliant. All models meet FCC Part-18, CISPR-11 and EN55011 class B emission Limits, IEC 60601-1-2:2014 and are designed to comply with UL/cUL, TUV T-mark and conformity assessment in CE marking. **All units are 100% burned in and tested.**

RoHS2
2011/65/EU



Doc. EA-0323

15W Interchangeable Medical Grade Power Supply

FEATURES:

- * Wide Operating Voltage, 80 to 275 VAC, 47 to 63 Hz
- * Interchangeable Plug
- * Single Output
- * Input to Output : 2MOPP
- * High ESD immunity
- * Suitable home healthcare environment
- * Suitable professional healthcare facility
- * 3 year warranty

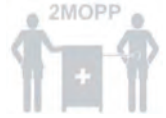

APPLICATIONS:

- * Breathing Therapy Device
- * Blood Pressure system
- * Portable medical device
- * ECG、EEG
- * Medical Tablet

GENERAL SPECIFICATION:

- * **Short Circuit Protection:** Auto Recovery
- * **Cooling:** Free Air Convection
- * **Flammability Rating:** UL94V-1
- * **Protection Classes:** Double insulated, Class II
- * **Safety:** IEC60601-1 Edition3.1, ES60601-1:2005(R2012), CSAC22.2 NO.60601-1:14, EN60601-1:2006/A1:2013, IEC60601-1-11

APPROVALS:



IP22

Electrical Characteristics:

Symbol	Characteristic	Condition	Min.	Typ.	Max.	Unit
Vins	Safety Approval Input Voltage Range	Safety Approval & Specification in Label	100		240	VAC
Vin	Input Operate Voltage Range	Detail to see Fig.1 (Derate linearly from 100% load at 90VAC to 80% load at 80VAC)	80		275	VAC
Fi	Input Frequency	Sine wave	47		63	Hz
Po	Output Power Range	See Rating Chart			15	W
Iil	Low Line Input Current	Full Load, Vin=100VAC		0.4		A
Iih	High Line Input Current	Full Load, Vin=240VAC		0.2		A
Irl	Low Line Input Inrush Current	Full Load, 25°C, Cool start, Vin=100VAC			50	A
Irh	High Line Input Inrush Current	Full Load, 25°C, Cool start, Vin=240VAC			115	A
η	Efficiency	Full Load, Vin=230VAC, Detail to see Rating Chart	See Rating Chart			
ΔVoi	Line Regulation	Full Load, Vin=100~120VAC or 200~240VAC			1	%
OLP	Over Load Protection	Recovers automatically after fault condition is removed	110		150	%
ttr	Time of Transient Response	Full Load, Vin=110VAC			4	ms
thu	Hold-Up Time	Full Load, Vin=110VAC	See Rating Chart			
ts	Start-up time	Full Load, Vin=100~240VAC			3	s
Tc	Temperature Coefficient	All Condition			±0.04	%/°C
HV	Dielectric Withstanding Voltage (P-S)	Primary to Secondary, limit current <10mA			4000	VAC
EMI	EMC Emission	Compliance to EN55011 (CISPR11), EN60601-1-2	B			Class

Environmental:

Symbol	Characteristic	Condition	Min.	Typ.	Max.	Unit
To	Operating Temperature	Detail to see Fig.2 (Derate linearly from 100% load at 40°C to 50% load at 70°C)	-10		70	°C
Ts	Storage Temperature	10 ~ 95% RH	-40		85	°C
Ho	Operating Humidity	non-condensing	0		95%	RH
Hs	Storage Humidity		0		95%	RH
ESDa	Electro Static Discharge	Air Discharge, IEC61000-4-2			15	kV
ESDc	Electro Static Discharge	Contact Discharge, IEC61000-4-2			8	kV
MTBF	Mean Time Between Failure	Operating Temperature at 25°C, Calculated per MIL-HDBK-217F	100k			h
ELEV	Operating Altitude (Elevation)	All condition			3000	m
VBR	Vibration	10 ~ 500Hz, 10min./1cycle, 60min. each along X, Y, Z axes			5	G
Vsl	Surge Voltage	Line-Neutral			1	kV
Vsg	Surge Voltage	Line-PE & Neutral-PE			2	kV

15W Interchangeable Medical Grade Power Supply

SPECIFICATION NOTE :

- Output can provide up to peak load when the power supply starts up. Continuous staying in more than rated load is not allowed.
- At factory, in 60% rated load condition, each output is checked to be within voltage accuracy.
- Line regulation is defined by changing $\pm 10\%$ of input voltage from nominal line at rated load.
- Load regulation is defined by changing $\pm 40\%$ of measured output load from 60% rated load.
- Ripple & noise is measured by using 20MHz bandwidth limited oscilloscope and terminated each output with a 0.47uF capacitor at rated load and nominal line.
- Hold up time is measured from the end of the last charging pulse to the time which the main output drops down to low limit of main output at rated load and nominal line.
- Efficiency is measured at rated load, and nominal line.

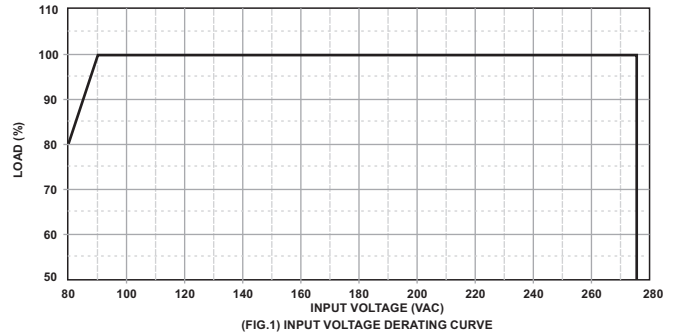

(FIG.1) INPUT VOLTAGE DERATING CURVE

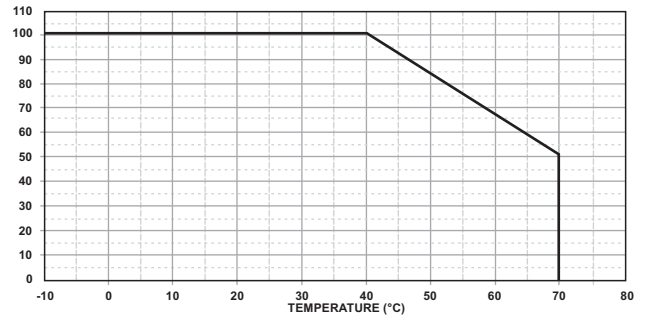

(FIG.2) TEMPERATURE DERATING CURVE

MECHANICAL DIMENSIONS: (UNIT: mm)

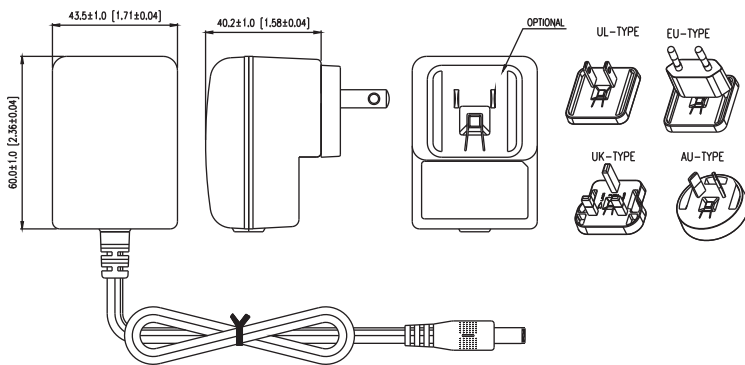

OUTPUT CABLE RECOMMEND :

- Selected output connectors and wire, please refer to Appendix.
- VPU15-102~104 are required to use AWG#18/4FT output cable.
- VPU15-105~109 are required to use AWG#20/4FT output cable.
- VPU15-110~111 are required to use AWG#22/4FT output cable.
- The regulation and efficiency will be changed by modified output cable.

PACKING :

- Net weight: 165g approx.
- Optional output connectors available contact sales for details.

Rating Chart:

MODEL NO.	Setting Voltage Range (Factory setting, can't be adjusted)		Output Current (Based on the output volt.)		Maximum Output Power (W)	Ripple & Noise (mVp-p)	Total Regulation (%)	Typ. Efficiency (%)	Typ. No Load Consumption (W)	Hold-Up Time (ms)	Protection Mode
	min	max	min	max							
	(VDC)	(VDC)	(A)	(A)							
VPU15-101	3.0	4.99	1.44	2.40	7.2	66	±5	70	0.2	10	Hiccup
VPU15-102	5.0	5.99	2.00	2.40	12	68	±5	74	0.3	10	Hiccup
VPU15-103	6.5	8.0	1.50	1.84	12	70	±5	78	0.3	10	Hiccup
VPU15-104	8.0	11.0	1.22	1.68	13.5	90	±5	79	0.3	10	Hiccup
VPU15-105	11.0	13.0	1.15	1.36	15	100	±5	81	0.3	10	Hiccup
VPU15-106	13.0	16.0	0.94	1.15	15	120	±5	82	0.3	10	Hiccup
VPU15-107	16.0	21.0	0.72	0.94	15	120	±5	82	0.3	10	Hiccup
VPU15-108	21.0	27.0	0.55	0.72	15	130	±5	83	0.3	10	Hiccup
VPU15-109	27.0	33.0	0.45	0.55	15	130	±3	83	0.3	10	Hiccup
VPU15-110	33.0	40.0	0.37	0.45	15	140	±3	84	0.3	10	Hiccup
VPU15-111	40.0	48.0	0.32	0.37	15	140	±3	84	0.3	10	Hiccup
VPU15-112	48.0	55.0	0.28	0.32	15	140	±3	84	0.3	10	Hiccup