

225 Watt Industrial

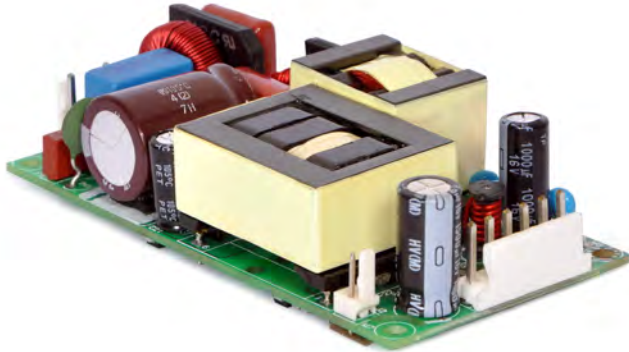

Features

- 4 x 2 x 1 Inches Form factor
- 225 Watts with Forced Air Cooling & 112.5 Watts Convection Cooling
- Efficiencies upto 94%
- -40 to 70 degree operating temperature*
- 12V Fan Output, Thermal Shut-Down feature
- > 800K Hours MTBF
- Standby Power < 0.5W

Electrical Specifications

Input Voltage	85-264 VAC/390 VDC, Universal (Derate from 100% at 100V AC to 95% at 85V AC)	
Input Frequency	47-63 Hz	
Input Current	115 VAC: 2.2 A max.	230 VAC: 1.1 A max.
No Load Power	less than 0.5W typical	
Inrush Current	115 VAC – 25 A, 230 VAC – 45 A, 264 VAC – 75 A	
Leakage Current	300 uA Typical, (N.A. For Class II Option)	Touch current <100uA
Efficiency	94%(48V), 93%(24V,30V), 92%(12V,15V)	
Hold-up Time	at 225W:10 ms ; 110W: 16 ms	
Power Factor	exceeds 0.95 with Full Load	
Output Power	225W with 13 CFM, 112.5W Convection	
Line Regulation	+/-0.5%	
Load Regulation	+/-0.5%	
Transient Response	25% step load change, at 0.1A/uS slew rate, 50% duty cycle, 50Hz=4% , recovery time < 5 ms	
Rise Time	55ms typical	
Set Point Tolerance	+/-1%	
Over Current Protection	>110%	
Over Voltage Protection	110 to 140%	
Short Circuit Protection	Hiccup mode	
Switching Frequency	PFC – 70 to 130 KHz ,PWM – 50-80 KHz	
Operating Temperature	-40 to +70°C, * -40 to 0°C startup is guaranteed with spec deviation	
Storage Temperature	-40 to +85°C	
Relative Humidity	5% to 95%, noncondensing	
Altitude	Operating: 10,000 ft.; Nonoperating: 40,000 ft.	
MTBF	> 800 kh; Bellcore TR-332	
Isolation Voltage	Input to Output – 3000V AC for ITE application Input to GND - 1500 VAC (Not Applicable For Class II Option)	
Cooling	225W with 13 CFM forced air cooling at 100 to 264VAC (refer Mechanical Drawing) 112.5W with natural convection cooling at 100 to 264VAC.	

Model Number	Description	Voltage	Max. Load (Convection)	Max. Load (13 CFM)	Min. Load	Ripple ¹
LP225-1001	with Screw Terminal	12 V	9.37A	18.75A	0.0 A	1%
LP225-1301	with Molex Connector	12 V	9.37A	18.75A	0.0 A	1%
LP225-1002	with Screw Terminal	15 V	7.5A	15A	0.0 A	1%
LP225-1302	with Molex Connector	15 V	7.5A	15A	0.0 A	1%
LP225-1003	with Screw Terminal	24 V	4.68A	9.37A	0.0 A	1%
LP225-1303	with Molex Connector	24 V	4.68A	9.37A	0.0 A	1%
LP225-1004	with Screw Terminal	48 V	2.34A	4.68A	0.0 A	1%
LP225-1304	with Molex Connector	48 V	2.34A	4.68A	0.0 A	1%
LP225-1005	with Screw Terminal	30 V	3.75A	7.5A	0.0 A	1%
LP225-1305	with Molex Connector	30 V	3.75A	7.5A	0.0 A	1%
LP225-1006	with Screw Terminal	58 V	1.94A	3.88A	0.0 A	1%
LP225-1306	with Molex Connector	58 V	1.94A	3.88A	0.0 A	1%
LP225-CK metal cover kit accessory						

Connectors		
J1	Pin 1	AC NEUTRAL
	Pin 2	NOT FITTED
	Pin 3	AC LINE
J2 Option 1 & 2	Pin 1,2,3	V1 +VE
	Pin 4,5,6	V1 -VE
J3	Pin 1	FAN -VE
	Pin 2	FAN +VE

Notes

- Ripple is peak to peak with 20 MHz bandwidth and 10 μ F (Tantalum capacitor) in parallel with a 0.1 μ F capacitor at rated line voltage and load ranges.
- Class II means without input Earth pin.
- Combined output power of main output, fan supply shall not exceed max. Power rating.
- Fan supply output voltage tolerance including set point accuracy, line and load regulation is +/-10% and Ripple and noise is less than 10%.
- Specifications are for nominal input voltage, 25°C unless otherwise stated.

Mechanical Specifications	
AC Input Connector (J1)	Molex: 26-60-4030 Mating: 09-50-3031; Pins: 08-50-0106
DC Output Connector (J2) Option 1 (Screw Terminal)	Molex: 39357 Series or equivalent
DC Output Connector (J2) Option 2 (Molex Connector)	Molex: 26-60-4060 Mating: 09-50-3061; Pins: 08-50-0106
Aux (Fan) Output(J3)	AMP :640456-2 Mating: 640440-2
Dimensions	4 x 2 x 1 inches (101.60 x 50.8x 25.4 mm)
Weight	200 gm approx
EMC	
CE Mark	Complies with LVD Directive
Conducted Emissions	EN55022-B, CISPR22-B, FCC PART15-B
Static Discharge	EN61000-4-2, Level-3
RF Field Susceptibility	EN61000-4-3, Level-3
Fast Transients/Bursts	EN61000-4-4, Level-3
Radiated Emissions	Level A radiated, Level B radiated with external core
Surge Susceptibility	EN61000-4-5, Level-3
Harmonic Current	EN61000-3-2, Class D
Safety	
Safety Standard(s)	EN60950-1, IEC60950-1 (ed.2), UL 60950 (ed.2), CSA C22.2 No.60950-1 (ed.2), Class1 SELV
Approval Agency	Nemko, UL, C-UL
Safety File Number(s)	(Pending)

Derating Curve

12V,15V,24V,30V,48V,58V Output

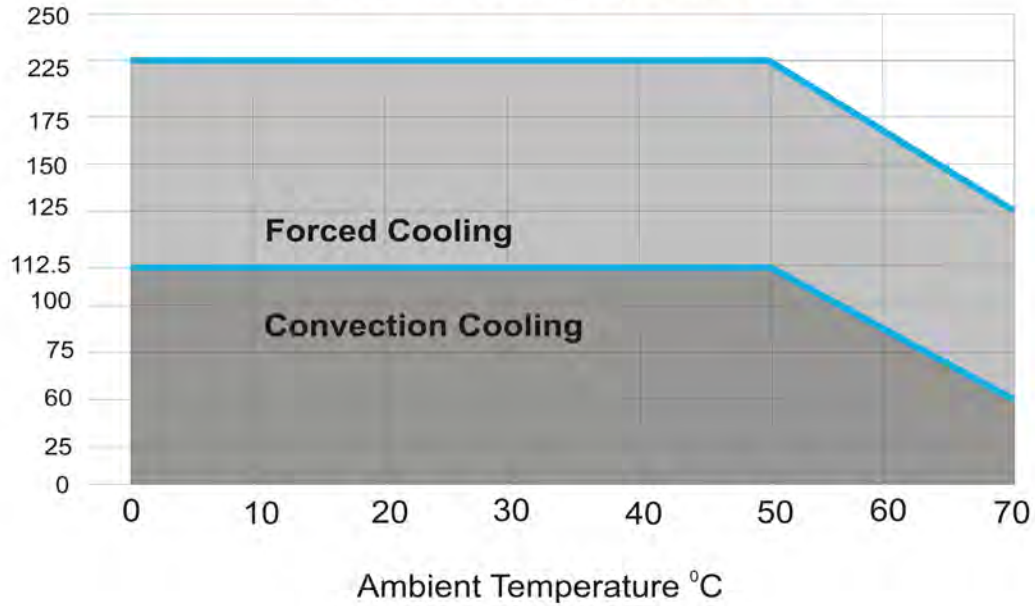

Mechanical Drawing

Option 1

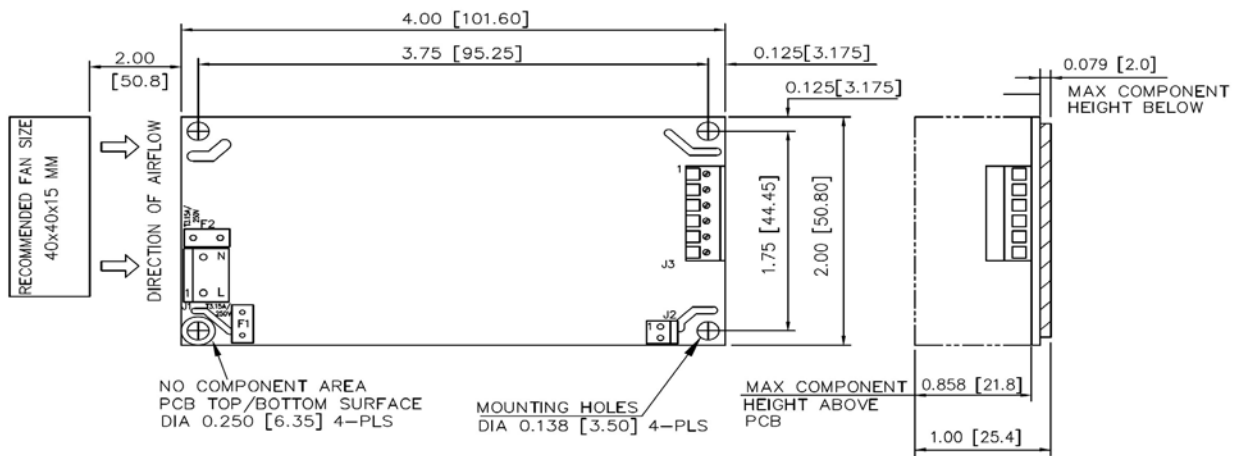

MECHANICAL OUTLINE DIMENSIONS
 ALL DIMENSIONS ARE IN INCHES[MM]
 GEN TOLERANCE : +/-0.02[0.5mm]

Mechanical Drawing

Option 2

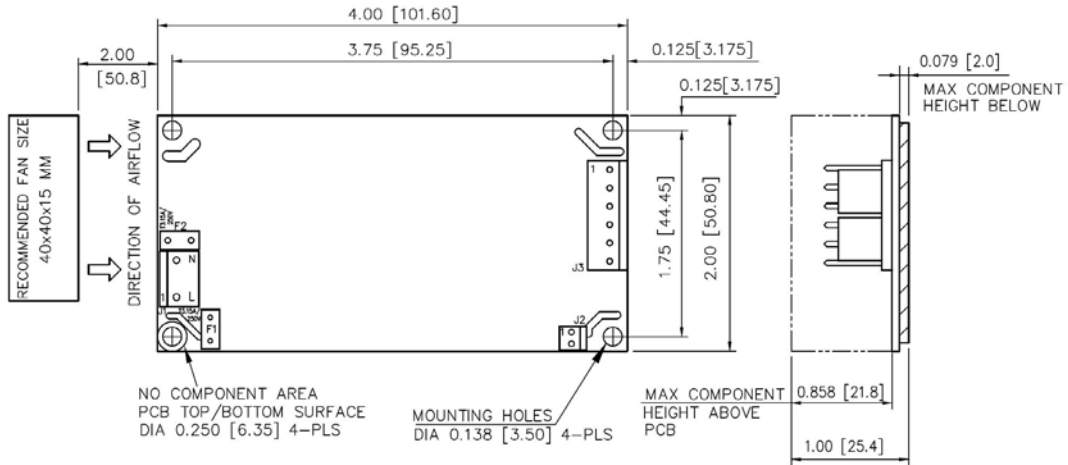

MECHANICAL OUTLINE DIMENSIONS
ALL DIMENSIONS ARE IN INCHES[MM]
GEN TOLETANCE : +/-0.02[0.5mm]