



Your Power House
VP ELECTRONIQUE

8cW95!\$&(\$

3PH AC - DC DIN RAIL MOUNTABLE POWER SUPPLY
INDUSTRIAL CONTROL EQUIPMENT



FEATURES

- 3 PHASE AC INPUT VOLTAGE
- SELV COMPACT DESIGN
- SHORT CIRCUIT PROTECTION
- INTERNAL INPUT FILER
- OVER TEMPERATURE PROTECTION
- PARALLEL FUNCTION AVAILABLE (SWITCH)



Three Phases

240 - 24

Wattage 24 : 24V OUT 48 : 48V OUT

MODEL LIST

MODEL NO.	INPUT VOLTAGE	OUTPUT WATTAGE	OUTPUT VOLTAGE	OUTPUT CURRENT	EFF. (min.)	EFF. (typ.)
Single Output Models						
240-24	3 ϕ 340~575 VAC	240 WATTS	+ 24 VDC	10 A	88%	90%
240-48	3 ϕ 340~575 VAC	240 WATTS	+ 48 VDC	5 A	89%	91%

SPECIFICATION

All Specifications Typical At Nominal Line, Full Load, 25°C Unless Otherwise Noticed

GENERAL

Characteristics	Conditions	min.	typ.	max.	unit
Switching frequency	Vi nom, Io nom		25		KHz
Isolation voltage	Input-Output	3,000 / 4,242			VAC / VDC
	Input-FG	1,500 / 2,121			VAC / VDC
	Output-FG	500 / 710			VAC / VDC
Isolation resistance	Input-Output, @ 500VDC	100			M Ω
Ambient temperature	Operating at Vi nom	-40		+ 71	°C
Derating (see derating curve)	Vi nom, from +61 to +71°C			2.5	% / °C
Storage temperature	Non operational	-40		+ 85	°C
Relative humidity	Vi nom, Io nom	20		95	% RH
Temperature coefficient	Vi nom, Io min			± 0.03	% / °C
MTBF	Bellcore Issue 6 @40°C, GB	24V	488,000		Hours
		48V	519,000		Hours
Altitude during operation	EN 60950-1			5,000	m
Dimension	Screw terminal type	L124 x W89 x D118.8			mm
Cooling	Free air convection				
Installation position	Vertical (other direction may derating using)				
Pollution degree			2		

INPUT SPECIFICATIONS

Characteristics	Conditions	min.	typ.	max.	unit
Nominal voltage *I			1 ϕ or 3 ϕ 380 / 480 VAC		
Rated input voltage	Io nom	400		500	VAC
Absolute input max. range	Ta min ... Ta max, AC in	340		575	VAC
	Io nom, DC in	480		820	VDC
Input current	Vi : 400 / 500 VAC, Io nom		0.65 / 0.55		A

*I. Single phase input is permissible, but output load is derated to 75%



SPECIFICATION

All Specifications Typical At Nominal Line, Full Load, 25°C Unless Otherwise Noticed

INPUT SPECIFICATIONS

Characteristics	Conditions	min.	typ.	max.	unit
Rated input current	Vi : 340 VAC, Io nom			0.85	A
Line frequency	Vi nom, Io nom	47		63	Hz
Inrush current	Vi nom, Io nom		20	25	A
Power dissipation	Vi : 400 VAC, Io nom	24V model	30		W
		48V model	24		W
Leakage current	Input-Output			0.25	mA
	Input-FG			3.5	mA
P.F.C. (Passive)	Vi nom, Io nom		0.55		

OUTPUT SPECIFICATIONS

Characteristics	Conditions	min.	typ.	max.	unit
Output voltage accuracy (Adjusted before shipment)	Vi nom, Io max	0		+ 1	%
Minimum load	Vi nom	0			%
Line regulation	Io nom, Vi min ...Vi max			± 1	%
Load regulation	Vi nom, Io min ...Io nom	single mode		± 1	%
		parallel mode		± 5	%
Voltage trim range	Vi nom, 0.8 Io nom	24V model	22.5	28.5	VDC
		48V model	47	56	VDC
Rated continuous loading	Vi nom	24V model	10 A @ 24Vdc / 8.4 A @ 28.5Vdc		
		48V model	5 A @ 48Vdc / 4.2 A @ 56Vdc		
Hold up time	Vi nom, Io nom	20			ms
Turn on time	Vi nom, Io nom			1,000	ms
	Vi nom, Io nom → with 7000 µF CAP			1,500	ms
Rise time	Vi nom, Io nom			150	ms
	Vi nom, Io nom → with 7000 µF CAP			500	ms
Fall time	Vi nom, Io nom			150	ms
Transient recovery time	Vi nom, I ~ 0.5 Io nom			2	ms
Ripple & noise	Vi nom, Io nom, BW = 20MHz			100	mV
Power back immunity	Vi nom, Io nom	24V model	35		VDC
		48V model	63		VDC
Capacitor load	Vi nom, Io nom			7,000	µF
DC ON indicator threshold at start up (Green LED)	Vi nom, Io nom	24V model	17.6	19.4	VDC
		48V model	37	43	VDC
DC LOW indicator threshold after start up (Red LED)	Vi nom, Io nom	24V model	17.6	19.4	VDC
		48V model	37	43	VDC
Parallel operation	0.1 Io min ~ 0.9 Io max			2	unit
Efficiency	Vi nom, Io nom, Po / Pi			Up to 91%, See model list and typ efficiency curve	

CONTROL AND PROTECTION

Characteristics	Conditions	min.	typ.	max.	unit
Input fuse		2 A / 600 VAC internal / phase			
Internal surge voltage protection	IEC 61000-4-5	Varistor			
Rated over load protection	Vi nom (see typ current limited curve)	120		140	%
Power Rdy (for 24V model only)	Threshold voltage of contact closed(at start up)	17.6		19.4	VDC
	Electrical isolation	500			VDC
	Contact rating at 60VDC			0.3	A
Over voltage protection	Vi nom, 0.8 Io nom (Auto Recovery)	24V model	30	33	VDC
		48V model	60	66	VDC
Output short circuit		Hiccup mode			
Over temperature	Detect on heat sink, shut down O/P voltage, recovers automatically after temperature goes down.	100		110	°C
Degree of protection		IP20			



SPECIFICATION

All Specifications Typical At Nominal Line, Full Load, 25°C Unless Otherwise Noticed

APPROVALS AND STANDARDS

UL / cUL	UL 508 Listed UL 60950-1 Recognized ISA 12.12.01(Class I, Division 2, Groups A, B, C and D)
TUV	EN 60950-1 EN 61558-1, EN 61558-2-16 (meet EN 60204-1)
CE	EN 61000-6-3, EN 55022 Class B, EN 61000-3-2, EN 61000-3-3 EN 61000-6-2, EN 55024, EN 61000-4-2 Level 4, EN 61000-4-3 Level 3 EN 61000-4-4 Level 4, EN 61000-4-5 L-N Level 3, L / N-FG Level 4 EN 61000-4-6 Level 3, EN 61000-4-8 Level 4, EN 61000-4-11 ENV 50204 Level 2, EN 61204-3
CQC	GB4943.1, GB9254, GB17625.1
Vibration resistance	meet IEC 60068-2-6 (Mounting by rail : 10-500 Hz, 2G, along X, Y, Z each Axis, 60 min for each Axis)
Shock resistance	meet IEC 60068-2-27 (15G, 11ms, 3 Axis, 6 Faces, 3 times for each Face)

PHYSICAL CHARACTERISTICS

Case size	Screw terminal type 124 x 89 x 118.8 mm (4.88 x 3.5 x 4.68 inches)
Case material	Metal
Weight	1100g
Packing	1.18kg ; 16pcs / 20kg / 2.01CUFT

MECHANISM & PIN CONFIGURATION

mm [inch]

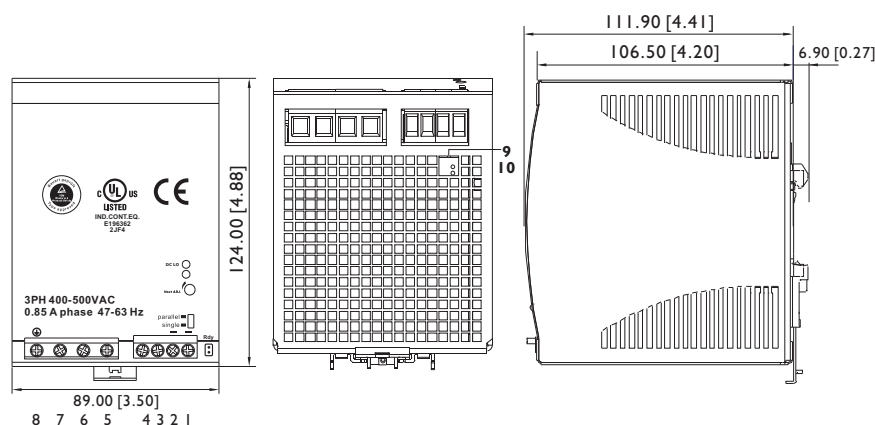

CONSTRUCTION

Easy snap-on mounting onto the DIN-Rail (TS35/7.5 or TS35/15), unit sits safely and firmly on the rail.

INSTALLATION

Ventilation / Cooling
Normal convection
All sides 25mm free space
For cooling recommended
Connector size range
AWG24-10 (0.2~4mm²) flexible / solid cable,
-Input connector can withstand torque at maximum 9 pound-inches.
-Output connector can withstand torque at maximum 5.5 pound-inches.
8 m/m stripping at cable end recommends
Use copper conductors only, 60 / 75°C

GENERAL TOLERANCE

0.00[0.00] - 30.00[1.18]	±0.30[0.01]
30.00[1.18] - 120.00[4.72]	±0.50[0.02]
120.00[4.72] - 400.00[15.75]	±0.80[0.03]

PIN ASSIGNMENT

PIN NO.	Designation	Description
1, 2	V -	Negative output terminal
3, 4	V +	Positive output terminal
5	L3	Input terminals
6	L2	Input terminals
7	L1	Input terminals
8	⊕	Ground this terminal to minimize high-frequency emissions
9	RDY	A normal open relay contact for DC ON level control (Never connect except 24V model)
10	DC ON	Operation indicator LED
	DC LO	DC LOW voltage indicator LED
	Vout ADJ.	Trimmer-potentiometer for Vout adjustment
	S / P	Single / Parallel select switch

CIRCUIT SCHEMATIC

• Block diagram

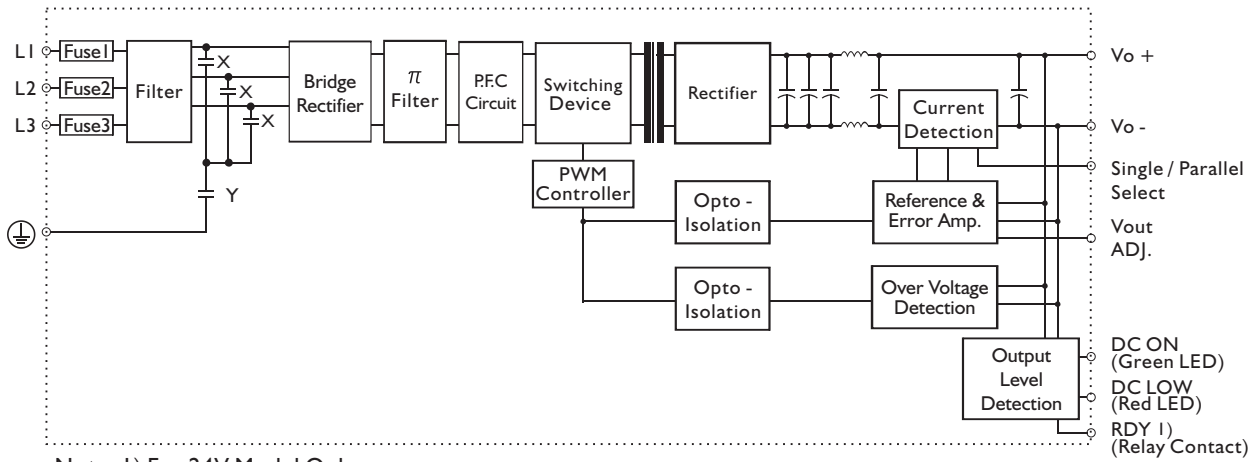

TYP. CURRENT LIMITED CURVE

240-24 / 400Vac

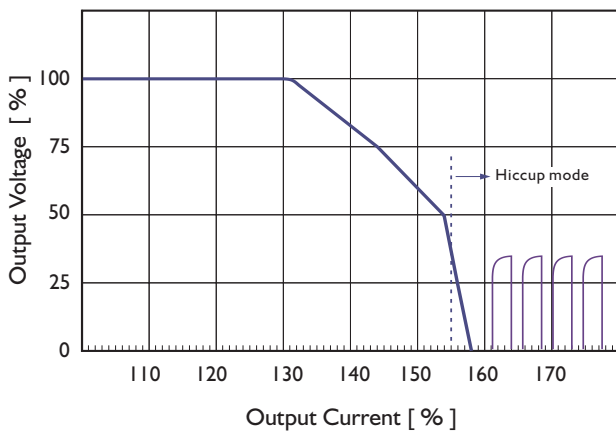

240-24 / 500Vac

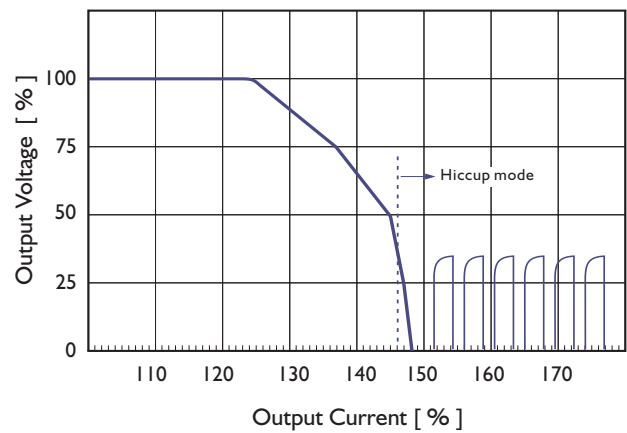

DERATING CURVE

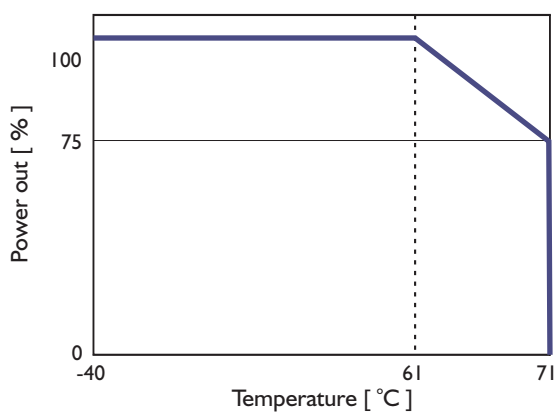

TYP. EFFICIENCY CURVE

