



Your Power House
VP ELECTRONIQUE

AC - DC DIN RAIL MOUNTABLE POWER SUPPLY
INDUSTRIAL CONTROL EQUIPMENT



FEATURES

- P.F.C FUNCTION AVAILABLE
- PARALLEL FUNCTION AVAILABLE (SWITCH)
- INPUT VOLTAGE 115/230VAC AUTO SELECT
- SELV COMPONENTS DESIGN



Power 240W or 300W

240 - 24 x

Wattage 24 : 24V OUT A : SCREW TERMINAL TYPE
48 : 48V OUT B : DETACHABLE CONNECTOR TYPE

MODEL LIST

MODEL NO.	INPUT VOLTAGE	OUTPUT WATTAGE	OUTPUT VOLTAGE	OUTPUT CURRENT	EFF. (min.)	EFF. (typ.)
Single Output Models						
240-24x	115 / 230 VAC	240 WATTS	+ 24 VDC	10 A	87%	89%
240-48x	115 / 230 VAC	240 WATTS	+ 48 VDC	5 A	88%	90%
300-24x	115 / 230 VAC	300 WATTS	+ 24 VDC	12.5A	87%	89%
300-48x	115 / 230 VAC	300 WATTS	+ 48 VDC	6.25A	88%	90%

SPECIFICATION

All Specifications Typical At Nominal Line, Full Load, 25°C Unless Otherwise Noticed

GENERAL						
Characteristics	Conditions	min.	typ.	max.	unit	
Switching frequency	Vi nom, Io nom		40		KHz	
Isolation voltage	Input-Output	3,000 / 4,242			VAC / VDC	
	Input-FG	1,500 / 2,121			VAC / VDC	
	Output-FG	500 / 710			VAC / VDC	
Isolation resistance	Input-Output, @ 500VDC	100			MΩ	
Ambient temperature	Operating at Vi nom	240	-40	+ 71	°C	
		300	-30	+ 71	°C	
Derating (see derating curve)	Vi nom, from +61 to +71°C	240		2.5	% / °C	
	Vi nom, from +56 to +71°C	300		2.5	% / °C	
Storage temperature	Non operational	-40		+ 85	°C	
Relative humidity	Vi nom, Io nom	20		95	% RH	
Temperature coefficient	Vi nom, Io min			± 0.03	% / °C	
MTBF	Bellcore Issue 6 @40°C, GB	240-24x		423,000		Hours
		240-48x		437,000		Hours
		300-24x		415,000		Hours
		300-48x		431,000		Hours
Altitude during operation	EN 60950-1			5,000	m	

SPECIFICATION

All Specifications Typical At Nominal Line, Full Load, 25°C Unless Otherwise Noticed

GENERAL

Characteristics	Conditions	min.	typ.	max.	unit
Dimension	Screw terminal type	L124.5 x W83.5 x D123.6			mm
	Detachable connector type	L143.5 x W83.5 x D123.6			mm
Cooling	Free air convection				
Installation position	Vertical (other direction may derating using)				
Pollution degree		2			

INPUT SPECIFICATIONS

Characteristics	Conditions	min.	typ.	max.	unit
Rated input voltage	Io nom	115 / 230 (auto select)			VAC
Absolute input max. range	Ta min ... Ta max, Io nom	AC in 115V selected	90	132	VAC
		AC in 230V selected	180	264	VAC
	DC in	210	375	VDC	
Input current	Vi : 115 / 230 VAC, Io nom	240	4.0 / 1.55		A
		300	4.8 / 1.9		A
Rated input current	Vi : 90 / 180 VAC, Io nom	240		5.4 / 2.2	A
		300		6.0 / 3.0	A
Line frequency	Vi nom, Io nom	47		63	Hz
Inrush current	Vi : 115 / 230 VAC , Io nom	240		30 / 60	A
		300		35 / 65	A
Power dissipation	Vi : 230 VAC, Io nom	240(24V/48V)	35 / 32		W
		300(24V/48V)	42 / 40		W
Leakage current	Input-Output			0.25	mA
	Input-FG			3.5	mA
P.F.C (Passive)	Vi : 230VAC, Io nom	240 / 300	0.75		

OUTPUT SPECIFICATIONS

Characteristics	Conditions	min.	typ.	max.	unit
Output voltage accuracy (Adjusted before shipment)	Vi nom, Io max	0		+ 1	%
Minimum load	Vi nom	0			%
Line regulation	Io nom, Vi min ...Vi max			± 0.5	%
Load regulation	Vi nom, Io min ...Io nom	single mode		± 1	%
		parallel mode		± 5	%
Voltage trim range	Vi nom, 0.8 Io nom	24V	22.5	28.5	VDC
		48V	47	56	VDC
Rated continuous loading	Vi nom	240-24x	10A @ 24Vdc / 8.4A @ 28.5 Vdc		
		240-48x	5A @ 48Vdc / 4.2A @ 56 Vdc		
		300-24x	12.5A @ 24Vdc / 10.5A @ 28.5 Vdc		
		300-48x	6.25A @ 48Vdc / 5.35A @ 56 Vdc		
Hold up time	Vi : 115 / 230 VAC , Io nom	25 / 30			ms
Turn on time	Vi nom, Io nom			1,000	ms
	Vi nom, Io nom → with 7000 µF CAP			1,500	ms
Rise time	Vi nom, Io nom			150	ms
	Vi nom, Io nom → with 7000 µF CAP			500	ms
Fall time	Vi nom, Io nom			150	ms
Transient recovery time	Vi nom, I ~0.5 Io nom			2	ms
Ripple & noise	Vi nom, Io nom, BW = 20MHz			100	mV
Power back immunity	Vi nom, Io nom	24V / 48V	35 / 63		VDC
Capacitor load	Vi nom, Io nom			7,000	µF
DC ON indicator threshold at start up (Green LED)	Vi nom, Io nom	24V	17.6	19.4	VDC
		48V	37	43	VDC
DC LOW indicator threshold after start up (Red LED)	Vi nom, Io nom	24V	17.6	19.4	VDC
		48V	37	43	VDC
Parallel operation	0.1 Io min ~ 0.9 Io max			3	unit
Efficiency	Vi nom, Io nom, Po / Pi	Up to 90%, See model list and typ efficiency curve			

SPECIFICATION

All Specifications Typical At Nominal Line, Full Load, 25°C Unless Otherwise Noticed

CONTROL AND PROTECTION

Characteristics	Conditions	min.	typ.	max.	unit
Input fuse		240	T6.3A / 250VAC internal		
		300	T8A / 250VAC internal		
Internal surge voltage protection	IEC 61000-4-5	Varistor			
Rated over load protection	Vi nom (see typ current limited curve)	120		145	%
Power Rdy (for 24V model only)	Threshold voltage of contact closed(at start up)	17.6		19.4	VDC
	Electrical isolation	500			VDC
	Contact rating at 60VDC			0.3	A
Over voltage protection	Vi nom, 0.8 Io nom (Auto Recovery)	24V	30	33	V
		48V	60	66	V
Output short circuit		Fold forward			
Degree of protection		IP20			

APPROVALS AND STANDARDS

UL / cUL	UL 508 Listed UL 60950-1 Recognized ISA 12.12.01(Class I, Division 2, Groups A, B, C and D)
TUV	EN 60950-1 EN 61558-1, EN 61558-2-16 (meet EN 60204-1)
CE	EN 61000-6-3, EN 55022 Class B, EN 61000-3-2 Class D, EN 61000-3-3 EN 61000-6-2, EN 55024, EN 61000-4-2 Level 4, EN 61000-4-3 Level 3 EN 61000-4-4 Level 4, EN 61000-4-5 L-N Level 3, L / N-FG Level 4 EN 61000-4-6 Level 3, EN 61000-4-8 Level 4, EN 61000-4-11 ENV 50204 Level 2, EN 61204-3
CCC	GB4943.1, GB9254, GB17625.1
Vibration resistance	meet IEC 60068-2-6 (Mounting by rail : 10-500 Hz, 2G, along X, Y, Z each Axis, 60 min for each Axis)
Shock resistance	meet IEC 60068-2-27 (15G, 11ms, 3 Axis, 6 Faces, 3 times for each Face)

PHYSICAL CHARACTERISTICS

Case size	Screw terminal type	124.5 x 83.5 x 123.6 mm (4.9 x 3.29 x 4.87 inches)
	Detachable connector type	143.5 x 83.5 x 123.6 mm (5.65 x 3.29 x 4.87 inches)
Case material	Metal	
Weight	240 : 1380g	300 : 1400g
Packing	240 : 1.5kg ; 16pcs / 25kg / 2.01CUFT	300 : 1.53kg ; 16pcs / 25.5kg / 2.01CUFT

MECHANISM & PIN CONFIGURATION

mm [inch]

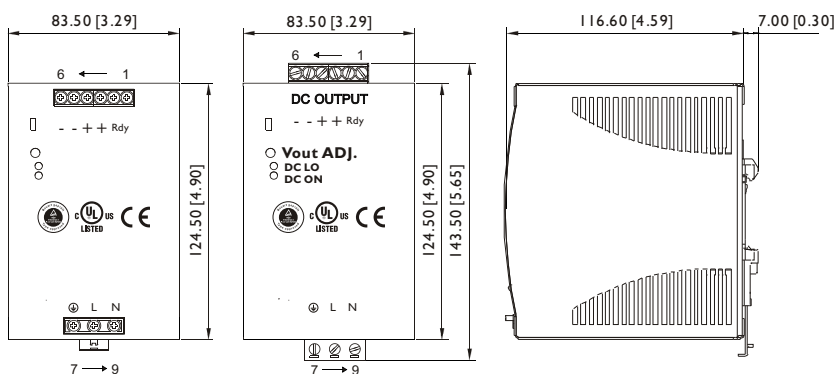

GENERAL TOLERANCE	
0.00[0.00] - 30.00[1.18]	±0.30[0.01]
30.00[1.18] - 120.00[4.72]	±0.50[0.02]
120.00[4.72] - 400.00[15.75]	±0.80[0.03]

CONSTRUCTION

Easy snap-on mounting onto the DIN-Rail (TS35/7.5 or TS35/15), unit sits safely and firmly on the rail.

INSTALLATION

Ventilation / Cooling
Normal convection
All sides 25mm free space
For cooling recommended
Connector size range
Screw terminal:
AWG24-10 (0.2~4mm²) flexible / solid cable,
-Input connector can withstand torque at maximum 9 pound-inches.
-Output connector can withstand torque at maximum 5.5 pound-inches.
8 m/m stripping at cable end recommends
Detachable connector:
AWG24-12 (0.2~2.5mm²) flexible / solid cable,
-Input connector can withstand torque at maximum 4.5 pound-inches.
-Output connector can withstand torque at maximum 7 pound-inches.
4~5 m/m stripping at cable end recommends
Use copper conductors only, 60 / 75°C

PIN ASSIGNMENT

PIN NO.	Designation	Description
1	OUT	RDY
2		A normal open relay contact for DC ON level control (Never connect except 24V model)
3, 4		V +
5, 6		V -
7	IN	⊕
8		L
9	N	Input terminals (neutral conductor, no polarity at DC input)
	OTHER	DC ON
		DC LO
		Vout ADJ.
		S / P

CIRCUIT SCHEMATIC

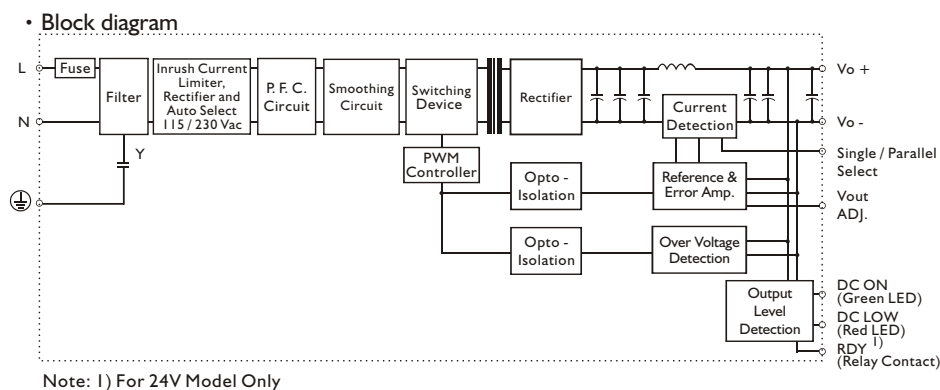

TYP. CURRENT LIMITED CURVE

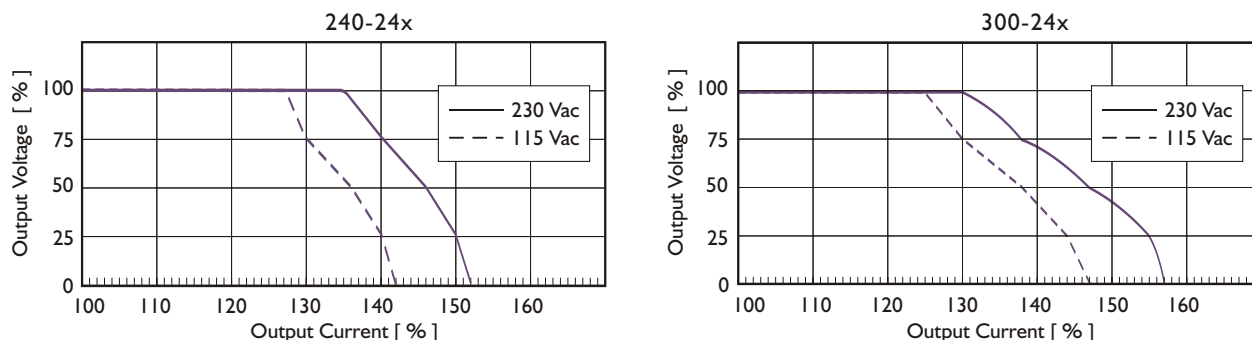

DERATING CURVE

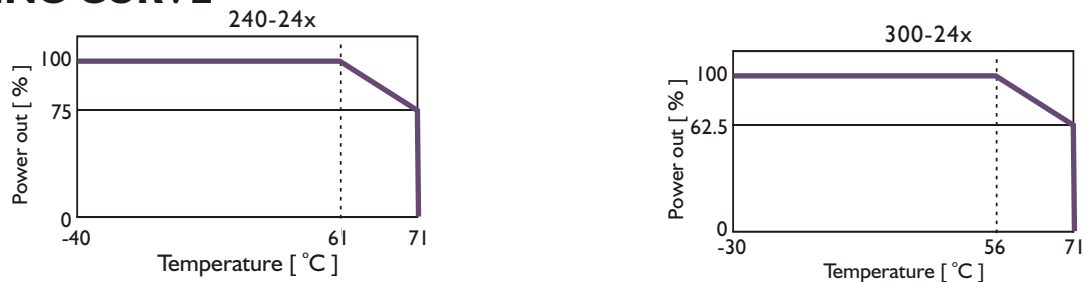

TYP. EFFICIENCY CURVE

