



8cW95!\$&' *

Your Power House
VP ELECTRONIQUE



2PH / Single PH AC - DC DIN RAIL MOUNTABLE
POWER SUPPLY
INDUSTRIAL CONTROL EQUIPMENT

FEATURES

- 2 PHASE / Single PHASE HIGH AC INPUT VOLTAGE
- SHORT CIRCUIT PROTECTION
- INTERNAL INPUT FILTER

6]d\ UgY ! 'G]b[`Y`D\ UgY



100 - 24
Wattage ————
12 : 12V OUT
24 : 24V OUT
48 : 48V OUT

MODEL LIST

MODEL NO.	INPUT VOLTAGE	OUTPUT WATTAGE	OUTPUT VOLTAGE	OUTPUT CURRENT	EFF. (min.)	EFF. (typ.)
Single Output Models						
100-12	2φ/1φ 340~575VAC	100.8 WATTS	+ 12 VDC	8.4 A	84%	86%
100-24	2φ/1φ 340~575VAC	100.8 WATTS	+ 24 VDC	4.2 A	85%	87%
100-48	2φ/1φ 340~575VAC	100.8 WATTS	+ 48 VDC	2.1 A	87%	89%

SPECIFICATION

All Specifications Typical At Nominal Line, Full Load, 25°C Unless Otherwise Noticed

GENERAL						
Characteristics	Conditions	min.	typ.	max.	unit	
Switching frequency	Vi nom, Io nom		85		KHz	
Isolation voltage	Input-Output	3,000 / 4,242			VAC / VDC	
	Input-FG	1,500 / 2,121			VAC / VDC	
	Output-FG	500 / 710			VAC / VDC	
Isolation resistance	Input-Output, @ 500VDC	100			MΩ	
Ambient temperature	Operating at Vi nom	-40		+ 71	°C	
Derating (see derating curve)	Vi nom, from +61 to +71°C			2.5	% / °C	
Storage temperature	Non operational	-40		+ 85	°C	
Relative humidity	Vi nom, Io nom	20		95	% RH	
Temperature coefficient	Vi nom, Io min			± 0.03	% / °C	
MTBF	Bellcore Issue 6 @40°C, GB	12V		622,000	Hours	
		24V		661,000	Hours	
		48V		672,000	Hours	
Altitude during operation	EN 60950-1			5,000	m	
Dimension	Screw terminal type			L90 x W54 x D114		mm
Cooling	Free air convection					
Installation position	Vertical (other direction may derating using)					
Pollution degree		2				



SPECIFICATION

All Specifications Typical At Nominal Line, Full Load, 25°C Unless Otherwise Noticed

INPUT SPECIFICATIONS

Characteristics	Conditions		min.	typ.	max.	unit
Nominal voltage			1 ϕ or 2 ϕ 380 / 480VAC			
Rated input voltage	Io nom		400		500	VAC
Absolute input max. range	Ta min ... Ta max, Io nom	AC in	340		575	VAC
		DC in	480		820	VDC
Input current	Vi : 400 / 500 VAC, Io nom			0.48 / 0.41		A
Rated input current	Vi : 340 VAC, Io nom				0.75	A
Line frequency	Vi nom, Io nom		47		63	Hz
Inrush current	Vi nom, Io nom			10	12	A
Power dissipation	Vi : 400 VAC, Io nom	12V		15		W
		24V		13.5		W
		48V		10.5		W
Leakage current	Input-Output				0.25	mA
	Input-FG				3.5	mA
P.F.C (Passive)	Vi nom, Io nom			0.55		

OUTPUT SPECIFICATIONS

Characteristics	Conditions		min.	typ.	max.	unit
Output voltage accuracy (Adjusted before shipment)	Vi nom, Io max		0		+ 1	%
Minimum load	Vi nom		0			%
Line regulation	Io nom, Vi min ... Vi max				\pm 1	%
Load regulation	Vi nom, Io min ... Io nom	single mode			\pm 1	%
		parallel mode			\pm 5	%
Voltage trim range	Vi nom, 0.8 Io nom	12V	11.4		14.5	VDC
		24V	22.5		28.5	VDC
		48V	47		56	VDC
Rated continuous loading	Vi nom	12V	8.4 A @ 12Vdc / 6.9 A @ 14.5 Vdc			
		24V	4.2 A @ 24Vdc / 3.5 A @ 28.5 Vdc			
		48V	2.1 A @ 48Vdc / 1.8 A @ 56 Vdc			
Hold up time	Vi nom, Io max		20			ms
Turn on time	Vi nom, Io nom				1,000	ms
	Vi nom, Io nom \rightarrow 12V, 24V models : with 7000 μ F CAP 48V model : with 3500 μ F CAP				1,500	ms
Rise time	Vi nom, Io nom				150	ms
	Vi nom, Io nom \rightarrow 12V, 24V models : with 7000 μ F CAP 48V model : with 3500 μ F CAP				500	ms
Fall time	Vi nom, Io nom				150	ms
Transient recovery time	Vi nom, I ~ 0.5 Io nom				2	ms
Ripple & noise	Vi nom, Io nom, BW = 20MHz				50	mV
Power back immunity	Vi nom, Io nom	12V model	18			VDC
		24V model	35			VDC
		48V model	63			VDC
Capacitor load	Vi nom, Io nom	12V, 24V models			7,000	μ F
		48V model			3,500	μ F
DC ON indicator threshold at start up (Green LED)	Vi nom, Io nom	12V model	10		11.2	VDC
		24V model	17.6		19.4	VDC
		48V model	37		43	VDC
DC LOW indicator threshold after start up (Red LED)	Vi nom, Io nom	12V model	10		11.2	VDC
		24V model	17.6		19.4	VDC
		48V model	37		43	VDC
Parallel operation	0.1 Io min ~ 0.9 Io max				2	unit
Efficiency	Vi nom, Io nom, Po / Pi		Up to 89%, See model list and typ efficiency curve			



SPECIFICATION

All Specifications Typical At Nominal Line, Full Load, 25°C Unless Otherwise Noticed

CONTROL AND PROTECTION

Characteristics	Conditions	min.	typ.	max.	unit
Input fuse		2A / 600VAC internal			
Internal surge voltage protection	IEC 61000-4-5	Varistor			
Rated over load protection	Vi nom (see typ current limited curve)	115		135	%
Power Rdy (for 24V model only)	Threshold voltage of contact closed(at start up)	17.6		19.4	VDC
	Electrical isolation	500			VDC
	Contact rating at 60VDC			0.3	A
Over voltage protection	Vi nom, 0.8 Io nom (Auto Recovery)	12V	15	16.5	VDC
		24V	30	33	VDC
		48V	60	66	VDC
Output short circuit		Hiccup mode			
Degree of protection		IP20			

APPROVALS AND STANDARDS

UL / cUL	UL 508 Listed UL 60950-1 Recognized ISA 12.12.01 (Class I, Division 2, Groups A, B, C and D)
TUV	EN 60950-1 EN 61558-1, EN 61558-2-16 (meet EN 60204-1)
CE	EN 61000-6-3, EN 55022 Class B, EN 61000-3-2, EN 61000-3-3 EN 61000-6-2, EN 55024, EN 61000-4-2 Level 4, EN 61000-4-3 Level 3 EN 61000-4-4 Level 4, EN 61000-4-5 L-N Level 3, L / N-FG Level 4 EN 61000-4-6 Level 3, EN 61000-4-8 Level 4, EN 61000-4-11 ENV 50204 Level 2, EN 61204-3
Vibration resistance	meet IEC 60068-2-6 (Mounting by rail : 10-500 Hz, 2G, along X, Y, Z each Axis, 60 min for each Axis)
Shock resistance	meet IEC 60068-2-27 (15G, 11ms, 3 Axis, 6 Faces, 3 times for each Face)

PHYSICAL CHARACTERISTICS

Case size	90 x 54 x 114 mm (3.6 x 2.13 x 4.49 inches)
Case material	Plastic
Weight	500g
Packing	0.57kg ; 32pcs / 19.5kg / 1.85CUFT

MECHANISM & PIN CONFIGURATION

mm [inch]

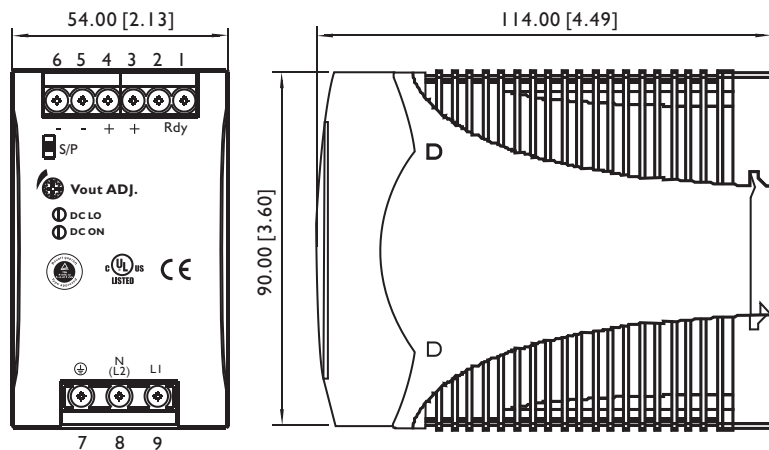

CONSTRUCTION

Easy snap-on mounting onto the DIN-Rail (TS35/7.5 or TS35/15), unit sits safely and firmly on the rail.

INSTALLATION

Ventilation / Cooling
Normal convection
All sides 25mm free space
For cooling recommended
Connector size range
AWG24-10 (0.2~4mm²) flexible / solid cable,
-Input connector can withstand torque at maximum 9 pound-inches.
-Output connector can withstand torque at maximum 5.5 pound-inches.
8 m/m stripping at cable end recommends
Use copper conductors only, 60 / 75°C

GENERAL TOLERANCE	
0.00[0.00] - 30.00[1.18]	±0.30[0.01]
30.00[1.18] - 120.00[4.72]	±0.50[0.02]



PIN ASSIGNMENT

PIN NO.	Designation	Description
1	OUT	RDY
2		A normal open relay contact for DC ON level control (Never connect except 24V model)
3, 4		V +
5, 6		V -
7	IN	⊕
8		N (L2)
9		LI
	OTHER	DC ON
		DC LO
		Vout ADJ.
		S / P

CIRCUIT SCHEMATIC

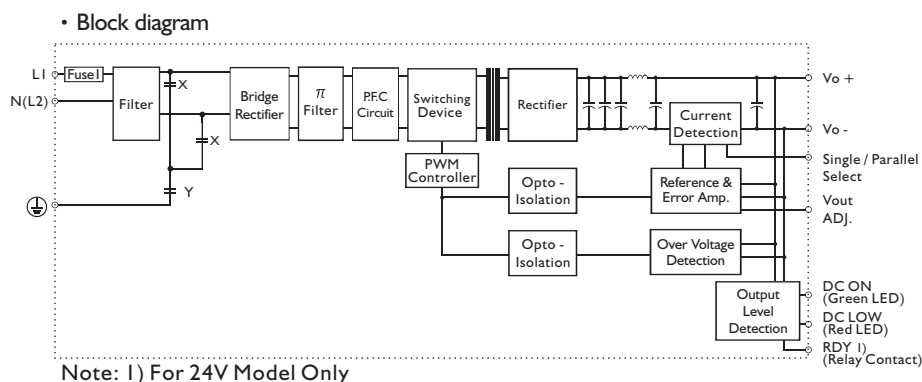

TYP. CURRENT LIMITED CURVE

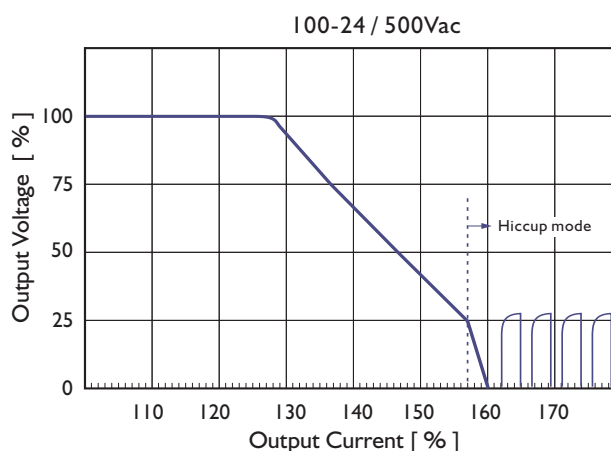
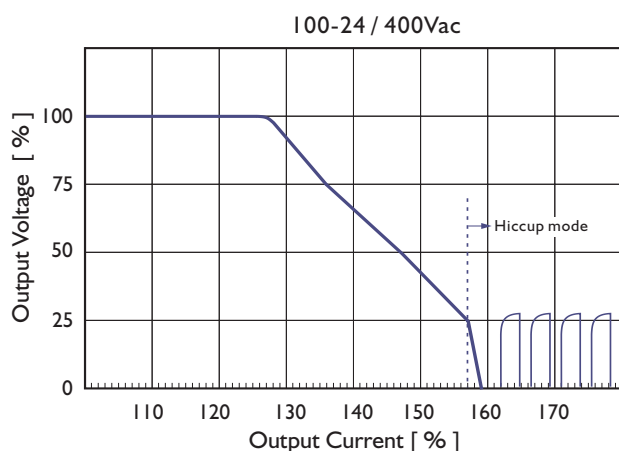

DERATING CURVE

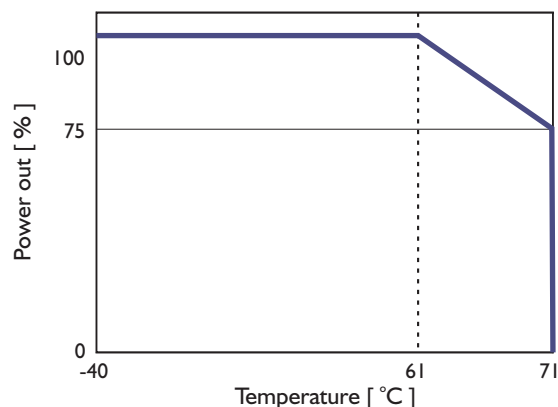

TYP. EFFICIENCY CURVE

