



Your Power House
VP ELECTRONIQUE

8cW95! \$&' ' .

AC - DC DIN RAIL MOUNTABLE POWER SUPPLY
INDUSTRIAL CONTROL EQUIPMENT



FEATURES

- UNIVERSAL INPUT 90~264VAC
- SHORT CIRCUIT PROTECTION
- INTERNAL INPUT FILTER



Power 5, 10, 15 or 18W

18- 24 x
 Wattage | |
 05 : 05V OUT 15 : 15V OUT BLANK : SPRING TERMINALS TYPE
 12 : 12V OUT 24 : 24V OUT A : SCREW TERMINALS TYPE

MODEL LIST

MODEL NO.	INPUT VOLTAGE	OUTPUT WATTAGE	OUTPUT VOLTAGE	OUTPUT CURRENT	EFF. (min.)	EFF. (typ.)
Single Output Models						
05-05(A)	90~264 VAC	5 WATTS	+ 5 VDC	1 A	67%	69%
05-12(A)	90~264 VAC	5 WATTS	+ 12 VDC	0.42 A	70%	72%
05-15(A)	90~264 VAC	5 WATTS	+ 15 VDC	0.34 A	70%	72%
05-24(A)	90~264 VAC	5 WATTS	+ 24 VDC	0.21 A	70%	72%
10-05(A)	90~264 VAC	10 WATTS	+ 5 VDC	2 A	71%	73%
10-12(A)	90~264 VAC	10 WATTS	+ 12 VDC	0.84 A	73%	75%
10-15(A)	90~264 VAC	10 WATTS	+ 15 VDC	0.67 A	74%	76%
10-24(A)	90~264 VAC	10 WATTS	+ 24 VDC	0.42 A	74%	76%
18-05(A)	90~264 VAC	15 WATTS	+ 5 VDC	3 A	73%	75%
18-12(A)	90~264 VAC	18 WATTS	+ 12 VDC	1.5 A	75%	77%
18-15(A)	90~264 VAC	18 WATTS	+ 15 VDC	1.2 A	75%	77%
18-24(A)	90~264 VAC	18 WATTS	+ 24 VDC	0.75 A	75%	77%

SPECIFICATION

All Specifications Typical At Nominal Line, Full Load, 25°C Unless Otherwise Noticed

GENERAL					
Characteristics	Conditions	min.	typ.	max.	unit
Switching frequency	Vi nom, Io nom		132		KHz
Isolation voltage	Input-Output	3,000 / 4,242			VAC / VDC
	Input-FG	1,500 / 2,121			VAC / VDC
	Output-FG	500 / 710			VAC / VDC
Isolation resistance	Input-Output, @ 500VDC	100			MΩ
Ambient temperature	Operating at Vi nom	-20		+ 71	°C

SPECIFICATION

All Specifications Typical At Nominal Line, Full Load, 25°C Unless Otherwise Noticed

GENERAL							
Characteristics	Conditions		min.	typ.	max.	unit	
Derating (see derating curve)	Vi nom, from +61°C to +71°C				2.5	% / °C	
Storage temperature	Non operational		-25		+ 85	°C	
Relative humidity	Vi nom, lo nom		20		95	% RH	
Temperature coefficient	Vi nom, lo min				± 0.03	% / °C	
MTBF	05	5V		802,000		Hours	
		Bellcore Issue 6 @40°C, GB	12V		805,000		Hours
			15V		808,000		Hours
			24V		812,000		Hours
	10	5V		801,000		Hours	
		Bellcore Issue 6 @40°C, GB	12V		803,000		Hours
			15V		805,000		Hours
			24V		808,000		Hours
	18	5V		795,000		Hours	
		Bellcore Issue 6 @40°C, GB	12V		797,000		Hours
			15V		796,000		Hours
			24V		800,000		Hours
Altitude during operation	EN 60950-1				5,000	m	
Dimension	Spring & Screw terminal type		L90 x W22.5 x D114			mm	
Cooling	Free air convection						
Installation position	Vertical (other direction may derating using)						
Pollution degree			2				

INPUT SPECIFICATIONS							
Characteristics	Conditions		min.	typ.	max.	unit	
Rated input voltage	lo nom		100		240	VAC	
Absolute input max. range	Ta min ... Ta max, lo nom	AC in	90		264	VAC	
		DC in	120		375	VDC	
Input current	Vi : 115 / 230 VAC, lo nom	DRA05		115 / 80		mA	
		DRA10		200 / 130		mA	
		DRA18		335 / 210		mA	
Rated input current	Vi : 90 VAC, lo nom	DRA05			200	mA	
		DRA10			300	mA	
		DRA18			500	mA	
Line frequency	Vi nom, lo nom		47		63	Hz	
Inrush current	Vi : 115 / 230 VAC , lo nom				10 / 18	A	
Power dissipation	05	5V		2.2		W	
		Vi : 230 VAC, lo nom	12V		1.9		W
			15V		2.1		W
			24V		1.8		W
	10	5V		4.0		W	
		Vi : 230 VAC, lo nom	12V		3.4		W
			15V		3.3		W
			24V		2.8		W
	18	5V		5.0		W	
		Vi : 230 VAC, lo nom	12V		4.65		W
			15V		4.25		W
			24V		4.45		W
Leakage current	Input-Output				0.25	mA	
	Input-FG				3.5	mA	

OUTPUT SPECIFICATIONS						
Characteristics	Conditions		min.	typ.	max.	unit
Output voltage accuracy (Adjusted before shipment)	Vi nom, lo max		0		+ 1	%
Minimum load	Vi nom		0			%
Line regulation	lo nom, Vi min ...Vi max				± 1	%

SPECIFICATION

All Specifications Typical At Nominal Line, Full Load, 25°C Unless Otherwise Noticed

OUTPUT SPECIFICATIONS

Characteristics	Conditions	min.	typ.	max.	unit
Line regulation	lo nom, Vi min ...Vi max			± 1	%
Load regulation	Vi nom, lo min ...lo nom			± 2	%
Voltage trim range	Vi nom, 0.8 lo nom	5V	4.5	5.75	V
		12V	10.8	13.8	V
		15V	13.5	17.25	V
		24V	21.6	28.8	V
Rated continuous loading	05 series Vi nom	5V	1.0 A @ 5Vdc / 0.85 A @ 5.75 Vdc		
		12V	0.42 A @ 12Vdc / 0.36 A @ 13.8 Vdc		
		15V	0.34 A @ 15Vdc / 0.28 A @ 17.25 Vdc		
		24V	0.21 A @ 24Vdc / 0.17 A @ 2 8.8 Vdc		
	10 series Vi nom	5V	2 A @ 5Vdc / 1.7 A @ 5.75 Vdc		
		12V	0.84 A @ 12Vdc / 0.72 A @ 13.8 Vdc		
		15V	0.67 A @ 15Vdc / 0.58 A @ 17.25 Vdc		
		24V	0.42 A @ 24Vdc / 0.34 A @ 2 8.8 Vdc		
	18 series Vi nom	5V	3 A @ 5Vdc / 2.6 A @ 5.75 Vdc		
		12V	1.5 A @ 12Vdc / 1.3 A @ 13.8 Vdc		
		15V	1.2 A @ 15Vdc / 1.0 A @ 17.25 Vdc		
		24V	0.75 A @ 24Vdc / 0.6 A @ 2 8.8 Vdc		
Hold up time	Vi : 115 / 230 VAC , lo nom	05	30 / 130		ms
		10	25 / 100		ms
		18	20 / 75		ms
Turn on time	Vi nom, lo nom	05 & 10		1,000	ms
				1,500	ms
	Vi nom, lo nom → with 3500 µF CAP	18		1,000	ms
				1,500	ms
Rise time	Vi nom, lo nom	05 & 10		150	ms
				500	ms
	Vi nom, lo nom → with 3500 µF CAP	18		150	ms
				500	ms
Fall time	Vi nom, lo nom			150	ms
Transient recovery time	Vi nom, I ~0.5 lo nom			2	ms
Ripple & noise	Vi nom, lo nom, BW = 20MHz			50	mV
Power back immunity	Vi nom, lo nom I second	5V	7.5		VDC
		12V	18		VDC
		15V	22		VDC
		24V	35		VDC
Capacitor load	Vi nom, lo nom	05 & 10		3,500	µF
			18		7,000
DC ON indicator threshold at start up (Green LED)	Vi nom, lo nom	5V	3.5	4.5	VDC
		12V	9.0	10.8	VDC
		15V	11.0	13.5	VDC
		24V	18	21.6	VDC
DC LOW indicator threshold after start up (Red LED)	Vi nom, lo nom	5V	3.5	4.5	VDC
		12V	9.0	10.8	VDC
		15V	11.0	13.5	VDC
		24V	18	21.6	VDC
Efficiency	Vi nom, lo nom, Po / Pi	Up to 77%, See model list and typ efficiency curve			

CONTROL AND PROTECTION

Characteristics	Conditions	min.	typ.	max.	unit
Input fuse		T2A / 250VAC internal			
Internal surge voltage protection	IEC 61000-4-5	Varistor			
Rated over load protection	Vi nom (see typ current limited curve)	110		145	%
Over voltage protection	Vi nom, 0.8 lo nom (Auto Recovery)	5V	6.25	7.25	V
		12V	15	17.4	V

SPECIFICATION

All Specifications Typical At Nominal Line, Full Load, 25°C Unless Otherwise Noticed

CONTROL AND PROTECTION

Characteristics	Conditions	min.	typ.	max.	unit
Over voltage protection	Vi nom, 0.8 Io nom (Auto Recovery)	15V	18.75	21.75	V
		24V	30	34.8	V
Output short circuit			Hiccup mode		
Degree of protection			IP20		

APPROVALS AND STANDARDS

UL / cUL	UL 508 Listed UL 60950-1, UL 1310 Class 2 Power Recognized ISA 12.12.01(Class I, Division 2, Groups A, B, C and D)
TUV	EN 60950-1
CE	EN 61000-6-3, EN 55022 Class B, EN 61000-3-2, EN 61000-3-3 EN 61000-6-2, EN 55024, EN 61000-4-2 Level 4, EN 61000-4-3 Level 3 EN 61000-4-4 Level 4, EN 61000-4-5 L-N Level 3, L / N-FG Level 4 EN 61000-4-6 Level 3, EN 61000-4-8 Level 4, EN 61000-4-11 ENV 50204 Level 2, EN 61204-3
CCC	GB4943.1, GB9254, GB17625.1
Vibration resistance	meet IEC 60068-2-6 (Mounting by rail : 10-500 Hz, 2G, along X, Y, Z each Axis, 60 min for each Axis)
Shock resistance	meet IEC 60068-2-27 (15G, 11ms, 3 Axis, 6 Faces, 3 times for each Face)

PHYSICAL CHARACTERISTICS

Case size	90 x 22.5 x 114 mm (3.6 x 0.89 x 4.49 inches)		
Case material	Plastic		
Weight	05 &	10 : 120 g	18 : 150 g
Packing	05 &	10 : 0.21 kg ; 56 pcs / 12.5 kg / 2.16 CUFT	
		18 : 0.23 kg ; 56 pcs / 14 kg / 2.16 CUFT	

MECHANISM & PIN CONFIGURATION

mm [inch]

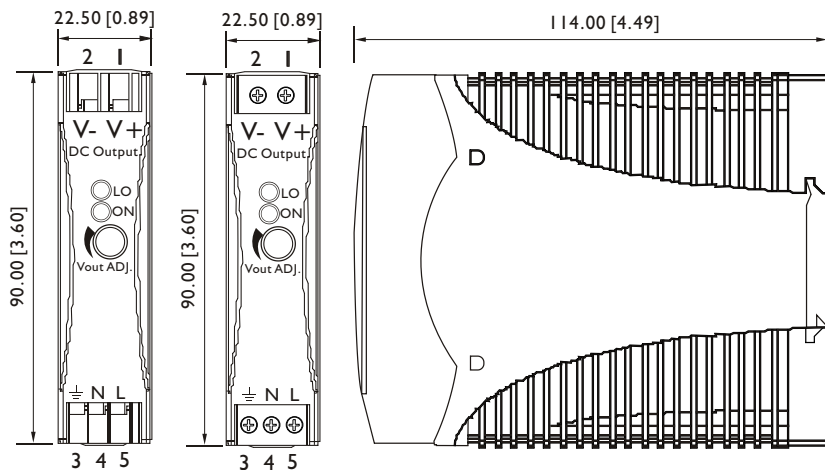

CONSTRUCTION

Easy snap-on mounting onto the DIN-Rail (TS35/7.5 or TS35/15), unit sits safely and firmly on the rail.

INSTALLATION

Ventilation / Cooling
Normal convection
All sides 25mm free space
For cooling recommended
Connector size range
Spring terminal:
AWG24-14 (0.2~2mm²) flexible / solid cable,
10 m/m stripping at cable end recommends
Screw terminal:
AWG26-12 (0.2~2.5mm²) flexible / solid cable,
connector can withstand torque at maximum 5
pound-inches.
4-5 m/m stripping at cable end recommends
Use copper conductors only, 60 / 75°C

GENERAL TOLERANCE	
0.00[0.00] - 30.00[1.18]	±0.30[0.01]
30.00[1.18] - 120.00[4.72]	±0.50[0.02]

PIN ASSIGNMENT

PIN NO.	Designation	Description
1	OUT	V + Positive output terminal
2		V - Negative output terminal
3	IN	⊥ Ground this terminal to minimize high-frequency emissions
4		N Input terminals (neutral conductor, no polarity at DC input)
5		L Input terminals (phase conductor, no polarity at DC input)
	OTHER	ON Operation indicator LED
		LO DC LOW indicator LED
		Vout ADJ. Trimmer-potentiometer for Vout adjustment

CIRCUIT SCHEMATIC

• Block diagram

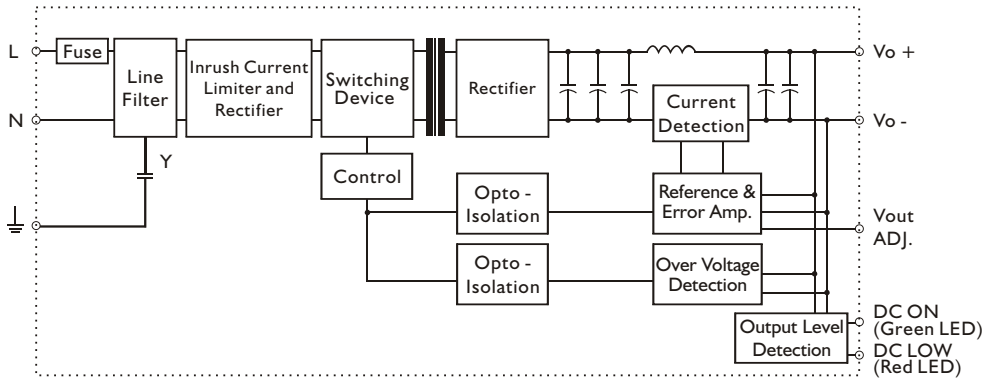

TYP. CURRENT LIMITED CURVE

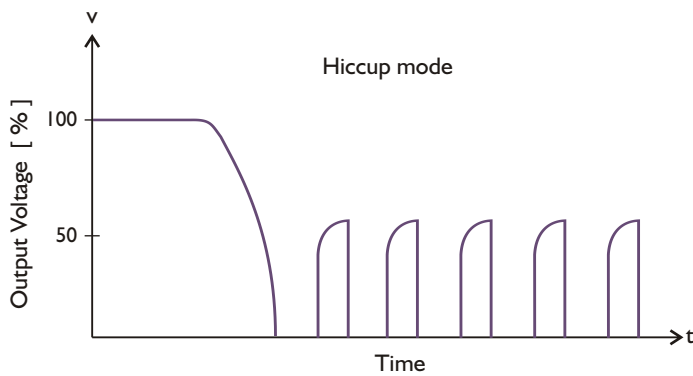

DERATING CURVE

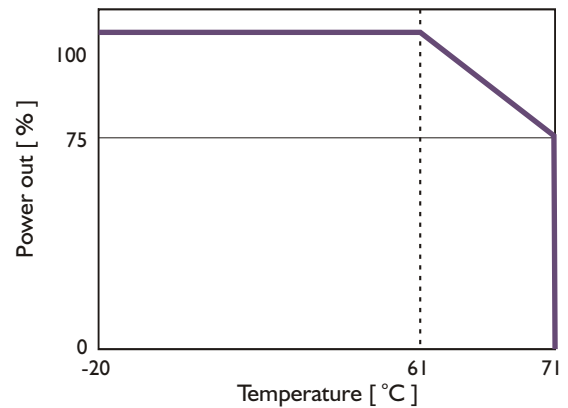

TYP. EFFICIENCY CURVE

