

Features:

- Universal AC input / Full range
- Programmable output Voltage (0% ~ 105%)
- Programmable output Current (0% ~ 105%)
- Forced current sharing at parallel operation
- Constant current limit
- Selectable +5V / 0.5A or +9V / 0.3A auxiliary output
- Global control via RS232
- Remote setting multiple PSU via RS232, RS485 & I²C
- Power OK signal
- Remote ON / OFF, Remote sense function
- Protection: OVP, OLP, OTP, Fan failure



MODEL		800-12	800-15	800-24	800-30	800-36	800-48	800-60
Output	DC Voltage Range	12V	15V	24V	30V	36V	48V	60V
	Rated Current	66.7A	53.4A	33.5A	26.7A	22.3A	16.7A	13.4A
	Current Range	0 ~ 66.7A	0 ~ 53.4A	0 ~ 33.5A	0 ~ 26.7A	0 ~ 22.3A	0 ~ 16.7A	0 ~ 13.4A
	Rated Power	800W	801W	804W	801W	802.8W	801.6W	804W
	Ripple & Noise (Max.)	Note.2 120mVp-p	150mVp-p	240mVp-p	300mVp-p	360mVp-p	480mVp-p	600mVp-p
	Voltage Adj. Range	±5.0% Typical adjustment by potentiometer. (VR1)						
	Voltage Tolerance	Note.3 ±2.0%						
	Line Regulation	±1.0%						
	Load Regulation	±1.0%						
	Setup, Rise Time	800ms, 100ms at full load						
Hold Up Time (Typ.)	14ms / 230VAC at full load							
Input	Voltage Range	Note.4 90 ~ 264VAC, 127 ~ 370VDC						
	Frequency Range	47 ~ 63Hz						
	Power Factor (Typ.)	0.95 / 230VAC, 0.98 / 115VAC at full load						
	Efficiency (Typ.)	89%	90%	92%	92%	92%	92%	93%
	AC Current (Typ.)	9.3A / 100VAC, 3.5A / 230VAC						
	Inrush Current (Typ.)	30A / 115VAC, 60A / 230VAC						
Leakage Current	< 1.0mA / 240VAC							
Protection	Over Load	105% rated output power, Protection type: Constant current limit						
	Over Voltage	Variable OVP, 120 ± 7% Vout. Refer to VCI VS OVP curve. Protection type: Latch-style (Recovery after reset AC power ON or inhibit)						
	Over Temperature	85 ±5°C detect on NTC, Protection type: Auto recovery after temperature goes down						
Function	Auxiliary Power	Selectable +5V / 0.5A or +9V / 0.3A auxiliary output						
	Remote ON / OFF Control	By external switch						
	Power OK Signal	Open drain signal low when PSU turns on, Max. sink current: 20mA, Max. drain voltage: 40V.						
	Output Voltage Trim	Adjustment of output voltage is between 0 ~ 105% of rated output						
	Output Current Trim	Adjustment of output current is between 0 ~ 105% of rated output						
Environment	Parallel (Current Sharing)	Note.5 Please refer to page 5						
	Address Setting	Up to 8 units can be set using an address switch (sw1), 0~7						
	Working Temp.	-20 ~ +60°C (Refer to de-rating curve)						
	Working Humidity	20 ~ 90% RH non-condensing						
	Storage Temp. & Humidity	-40 ~ +85°C, 10 ~ 95% RH						
Safety & EMC	Temp. Coefficient	±0.02% / °C (0 ~ 50°C)						
	Vibration	10 ~ 500Hz, 2G 10min. / 1cycle, period for 60min. each along X, Y, Z axes Compliance to IEC 68-2-6, IEC 68-2-64						
	Safety Standards	Certified UL 60950-1; EN 60950-1						
	Withstand Voltage	Note.7 I/P-O/P: 3KVAC (4242VDC), I/P-FG: 1.5KVAC (2121VDC), O/P-FG: 0.5KVAC (707VDC)						
	Isolation Resistance	I/P-O/P, I/P-FG, O/P-FG: 100M Ohms / 500VDC						
	EMI Conduction & Radiation	Certified EN 55022; EN 61204-3; EN 61000-6-3						
	Harmonic Current	Certified EN 61000-3-2; EN 61000-3-3						
Others	EMS Immunity	Certified EN 55024; EN 61204-3; EN 61000-6-1; IEC 61000-4-2, 3, 4, 5, 6, 8, 11						
	Cooling	Load and temperature control fan						
Note	Dimension (WxHxD)	127x41x249 mm / 5.000x1.614x9.803 inch						
	Packing	1.7kg; 6pcs / 11.2kg / 0.55CUFT						
<p>1. All parameters NOT specially mentioned are measured at 230VAC input, rated load and 25°C of ambient temperature. 2. Ripple & noise are measured at 20MHz of bandwidth by using a 12" twisted pair-wire terminated with a 0.1uF & 47uF parallel capacitor. 3. Tolerance: includes setup time tolerance, line regulation and load regulation. 4. De-rating may apply in low input voltage. Please check the de-rating curve for more details. 5. In parallel connection only one unit will operate if the total output load is less than 5% of the rated power. 6. The power supply is considered a component which will be installed into a final equipment. The final equipment must be re-confirmed that it still meets EMC directives. 7. This test done without enclosure.</p>								

Mechanical Drawings:

Unit:mm / inch

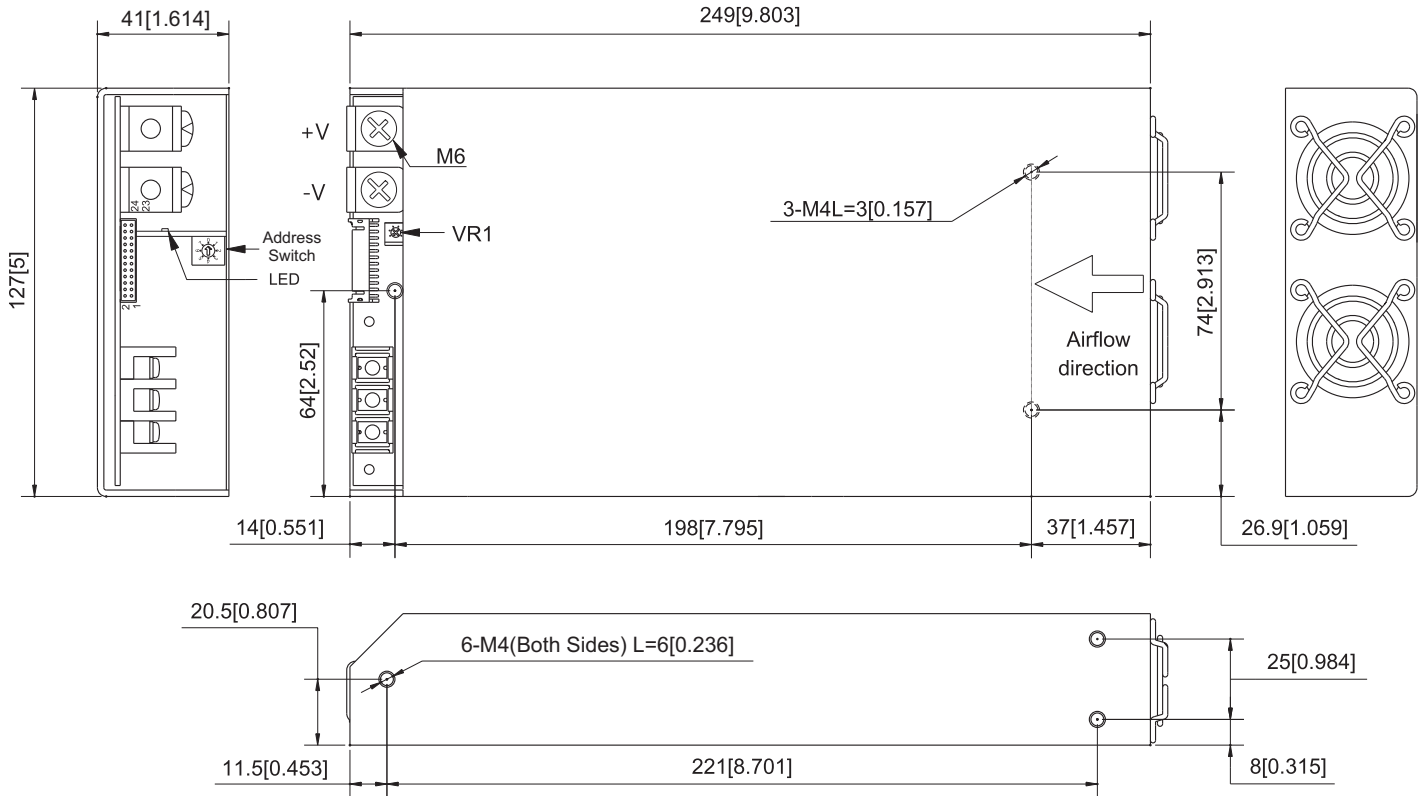

AC Input Terminal
Pin No. Assignment

Pin No.	Assignment
1	ACL
2	ACN
3	⏏

Control pin number assignment (CN2): JST S24B-PHDSS or equivalent

Pin No.	Assignment	Pin No.	Assignment	Pin No.	Assignment	Pin No.	Assignment	Pin No.	Assignment	Mating Housing / Contact	
1	NC.	6	SDA	11	ACI	16	GND	21	VS-	JST PHDR-24VS or equivalent	JST SPHD-002T-P0.5 or equivalent
2	NC.	7	AUX	12	GND	17	PAR	22	VO-		
3	AUX	8	GND	13	EN+	18	VSET	23	VS+		
4	GND	9	VCI	14	AUX	19	POK	24	VO+		
5	SCL	10	GND	15	EN-	20	GND				

CN2 Function Description:

Pin No.	Function	Description	Pin No.	Function	Description
1	NC.	For RS232 Receiver function	13	EN+	Inhibit ON/OFF (+)
2	NC.	For RS232 Transmission function	14	AUX	+5V / 0.5A or +9V / 0.3A Auxiliary power
3	AUX	+5V / 0.5A or +9V / 0.3A Auxiliary power	15	EN-	Inhibit ON/OFF (-)
4	GND	Ground	16	GND	Ground
5	SCL	Serial Clock used in the I ² C interface	17	PAR	Parallel operation current share
6	SDA	Serial Data used in the I ² C interface	18	VSET	Aux output setting
7	AUX	+5V / 0.5A or +9V / 0.3A Auxiliary power	19	POK	Power OK
8	GND	Ground	20	GND	Ground
9	VCI	V Program	21	VS-	Remote sense (-)
10	GND	Ground	22	VO-	Negative output voltage
11	ACI	I Program	23	VS+	Remote sense (+)
12	GND	Ground	24	VO+	Positive output voltage

Remote ON/OFF:

(A) Default Setting

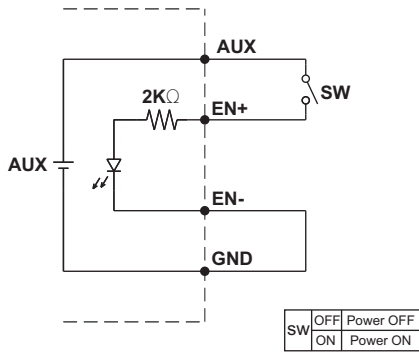

(A) Using internal 5V auxiliary source

(B)

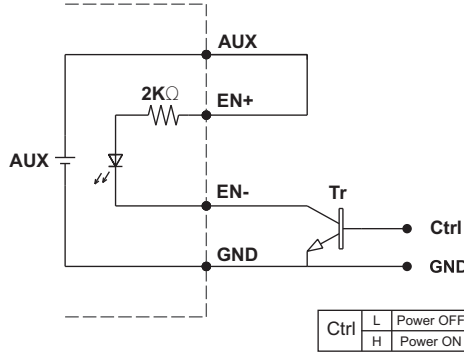

(B) ON / OFF Control by NPN transistor

(C)

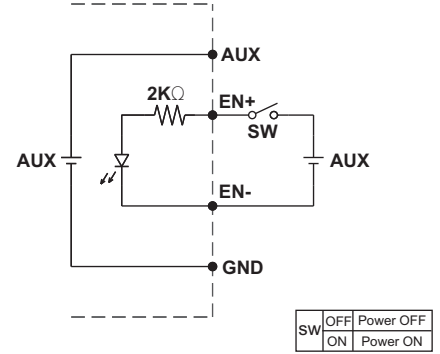

(C) Using external voltage source

Power OK Signal:

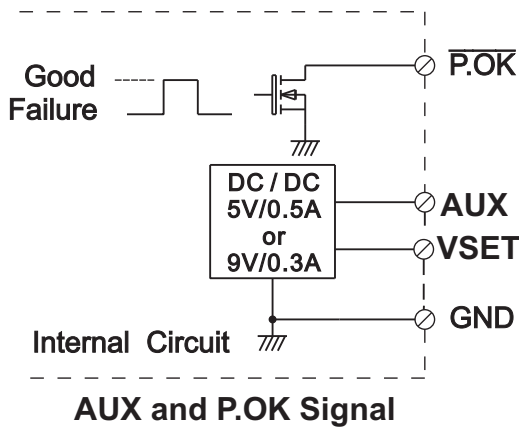

*Place an additional capacitor to have a better performance of auxiliary power operation.

*The grounding of "AUX" power should be connected to "GND" port. If "V-" is connected as Grounding, make sure to short the GND and V- ports.

VSET	Open(Default Setting)	5V
	Short To GND	9V

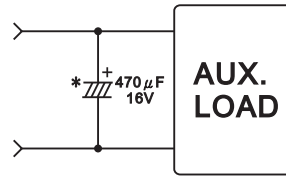

1. Remote Sense

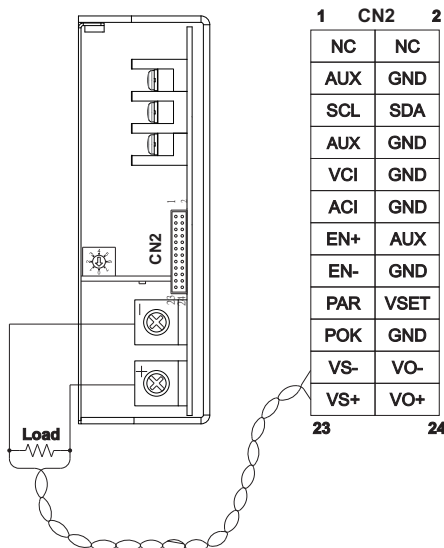

2. Local Sense (Default setting)

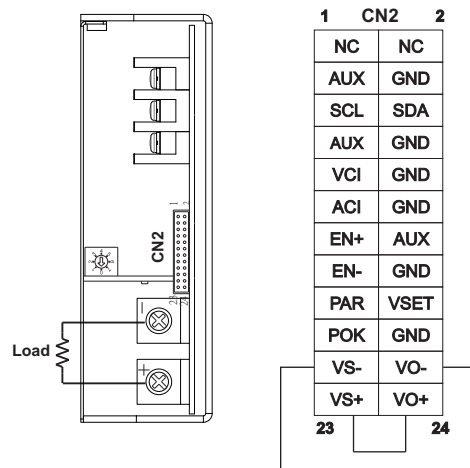

3. Current Sharing with Remote Sensing

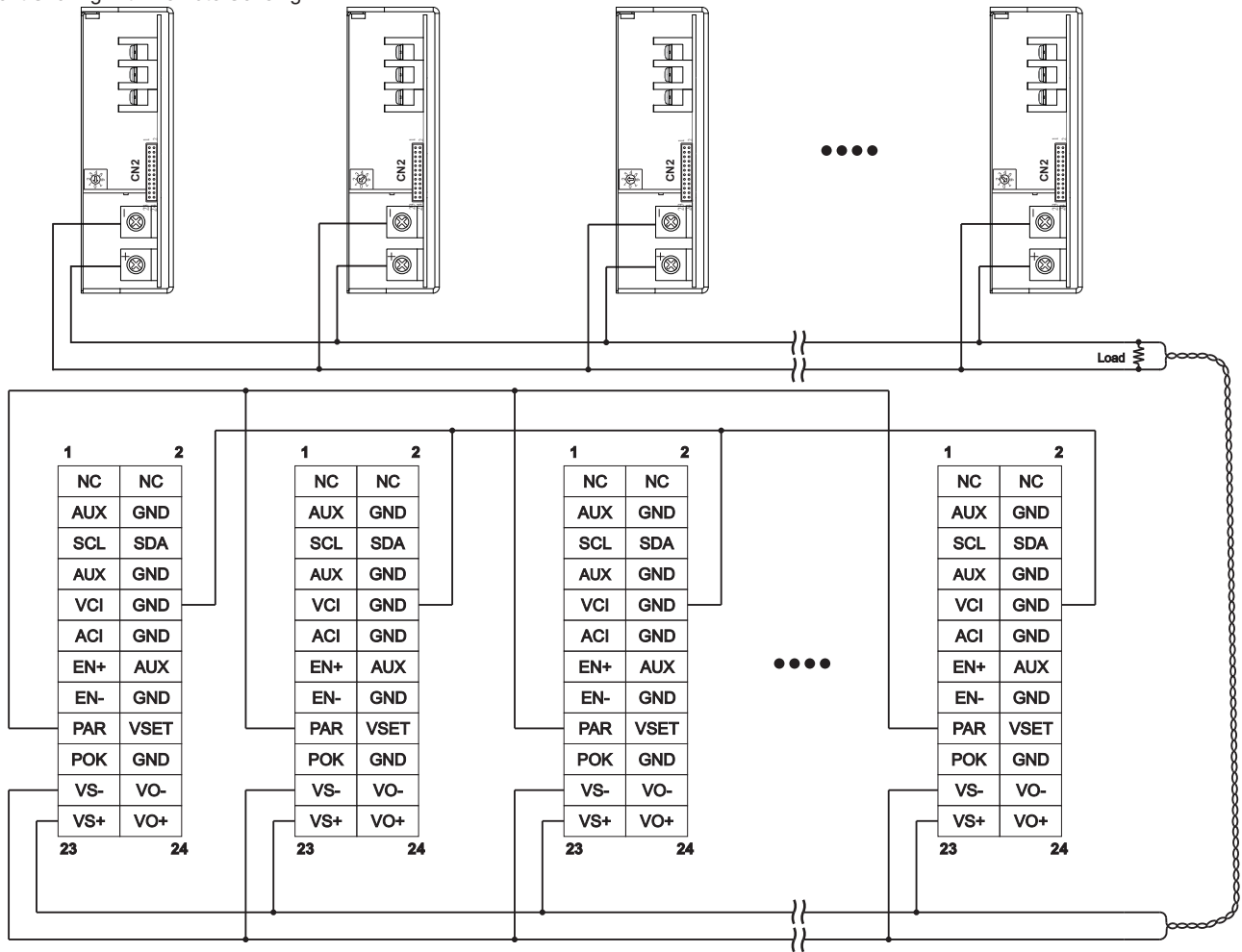

4. Current Sharing with Local Sensing

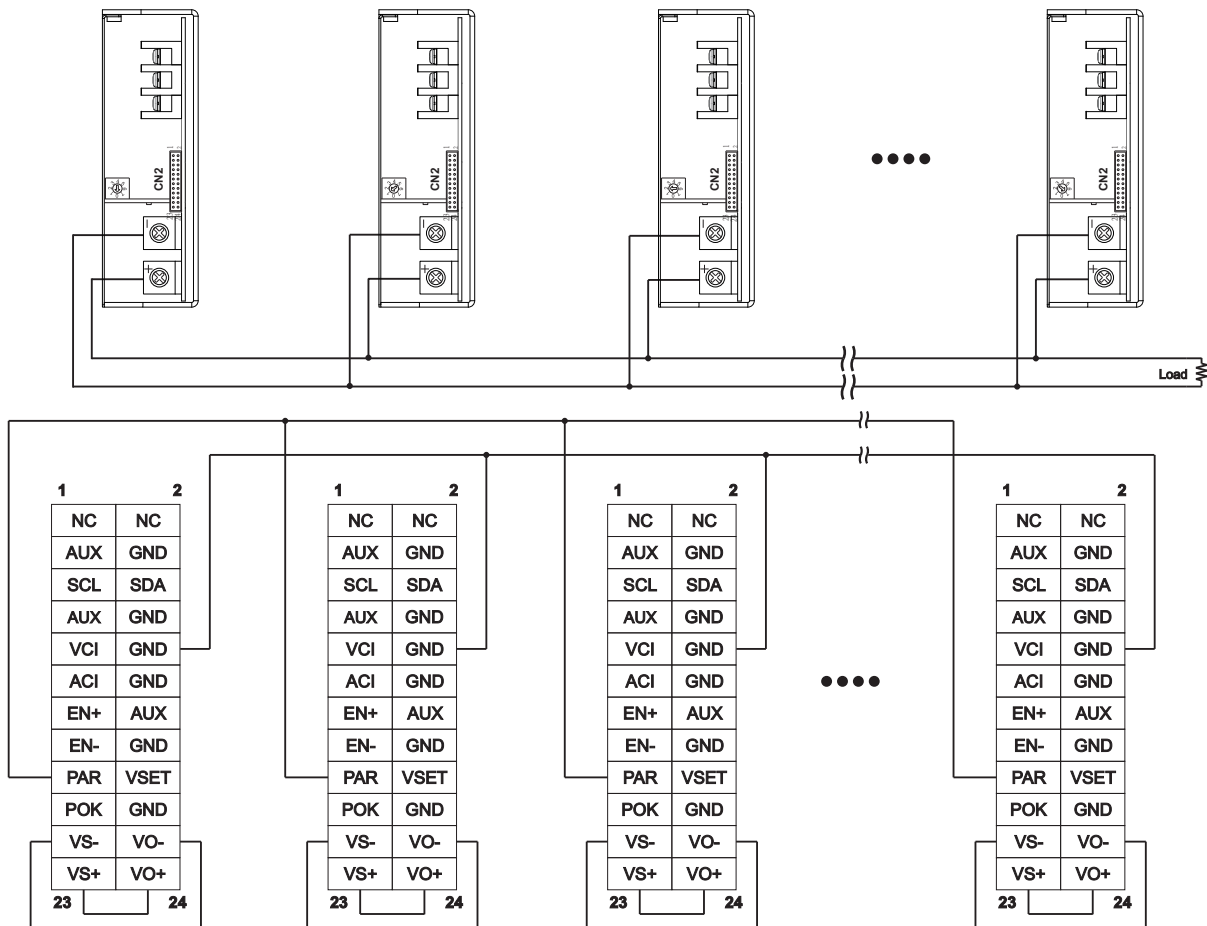

Installation Instruction:

1. Mounting Directions

1-1 Recommended standard mounting methods:

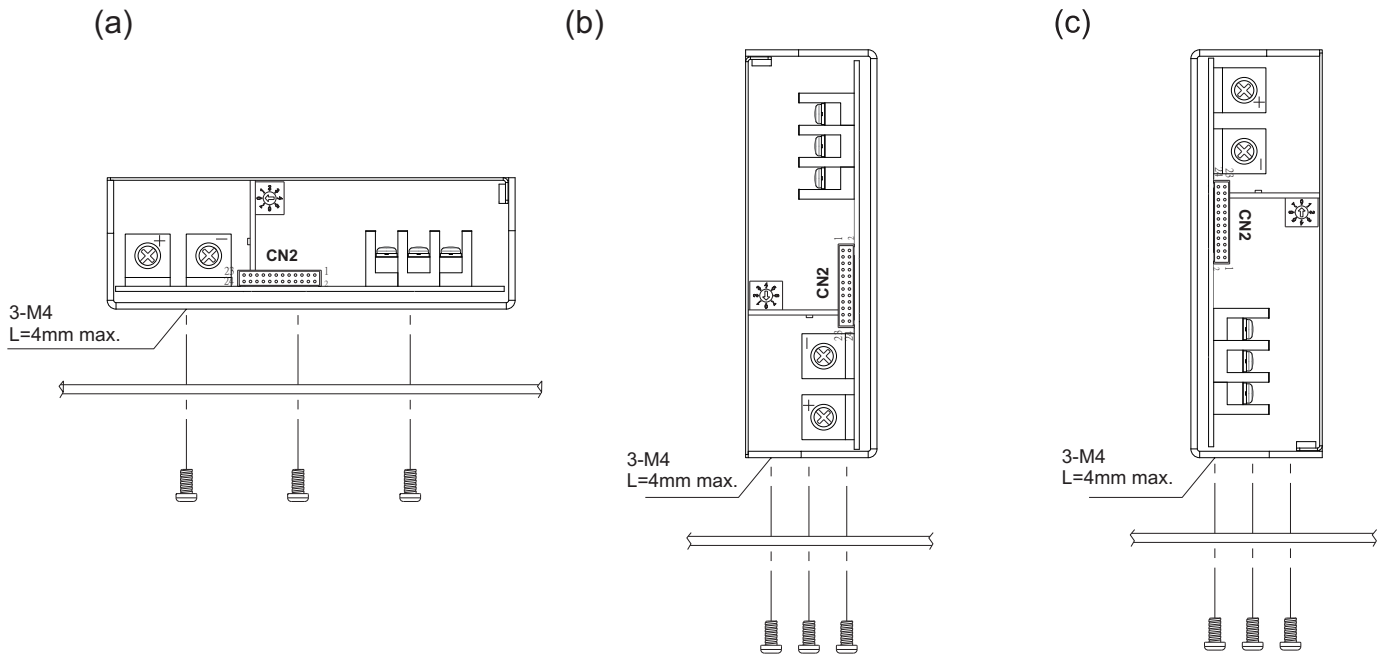

2. Mounting Method

2-1 There are ventilating holes on the front and back side panels, do not obstruct; allow 50mm at least for air flow.

2-2 The Maximum allowable penetration of screw is 4mm. Incomplete threading should not be penetrated.

2-3 Recommended the torque of mounting screw:
M4 screw: 1.27N • m (13.0kgf • cm)

